



JANSON CONTROLS

Professional manufacturer in electric drive
and industry control since 2012



FC200 Series Vector General Purpose Frequency Inverter User Manual Book

Contents

- 1 Chapter 1 Safety Information and Precautions**
- 2 Chapter 2 Product Information**
- 3 Chapter 3 Mechanical Installation**
- 4 Chapter 4 Electrical Installation**
- 5 Chapter 5 Operation**
- 6 Chapter 6 Brief Introduction of Function Parameters**
- 7 Chapter 7 Troubleshooting and Maintenance**
- 8 Chapter 8 Accessories Selection**
- A Appendix A MODBUS Communication Protocol**
- B Appendix B European Fire Mode Functional Applications**

Contents

Preface	1
Chapter 1 Safety Information and Precautions	13
1.1 Security definition	13
1.2 Motor and mechanical load related.....	13
1.3 Inverter related.....	15
Chapter 2 Product Information	17
2.1 Model.....	17
2.2 Nameplate	17
2.3 Rated value.....	17
2.4 Technical specifications.....	19
Chapter 3 Mechanical Installation	22
3.1 Installation precautions.....	22
3.2 Installation site requirements.....	22
3.3 Installation direction and space	23
3.4 Outlook dimensions and Installation dimensions.....	24
Chapter 4 Electrical Installation	27
4.1 Wiring precautions.....	27

4.2 Peripheral device selection.....	28
4.3 Control panel description	31
4.4 Installation instructions for compliance with EMC requirements.....	40
Chapter 5 Operation	47
5.1 Explain.....	47
Chapter 6 Brief Introduction of Function Parameters.....	54
6.1 Brief table of basic function parameters	54
Chapter 7 Troubleshooting and Maintenance	109
7.1 Troubleshooting	109
7.2 Maintenance	115
Chapter 8 Accessories Selection.....	119
8.1 Operator panel mounting kit	119
8.2 Selection of braking unit and braking resistor.....	119
Appendix A MODBUS Communication Protocol.....	122
Appendix B European Fire Mode Functional Applications.	139
Product after-sales service policy.....	141

Preface

Thank you for purchasing the FC200 series vector general purpose frequency inverter developed by Our company.

This manual introduces how to use FC200 series frequency inverter correctly, and comprehensively introduces the functional characteristics and usage methods of FC200 frequency inverter, including product selection, parameter setting, operation debugging, maintenance inspection and other detailed information. Before use, please read this manual carefully. At the same time, please use the product after fully understanding the safety precautions of the product.

Precautions

In order to illustrate the details of the product, the illustrations in this manual sometimes show the state where the cover or safety cover is removed. When using this product, please be sure to install the case or cover according to the regulations, and operate according to the contents of the manual.

Illustrations in this manual are for illustration only and may differ from the product you ordered.

The company is committed to the continuous improvement of products, and product functions will be continuously upgraded. The information provided is subject to change without prior notice.

Connections to Peripherals

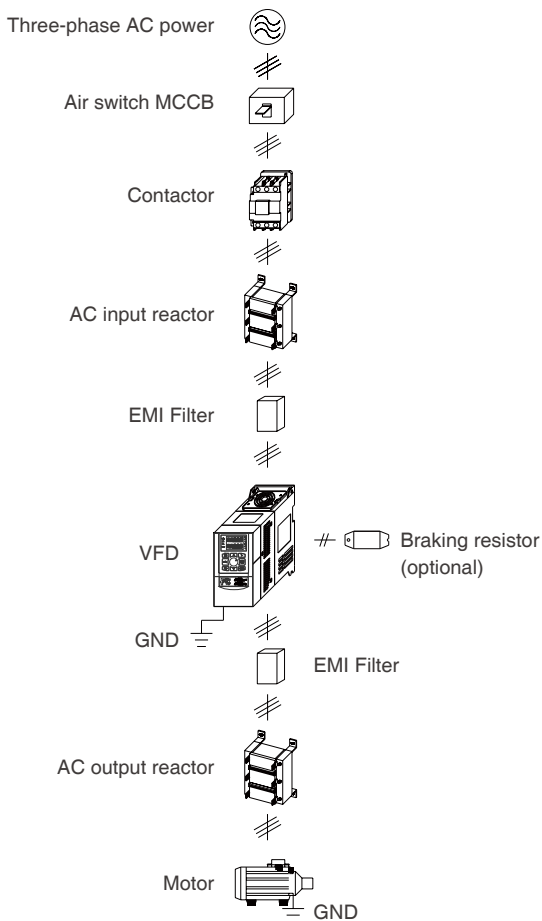

Basic Application Quick Start

Note:Some parameters have been set before leaving the factory (factory value), and you don't need to set them for the first time.

1. Correctly set the rated parameters of the motor.

Power on, use the operation panel to set the parameters in the table below, and refer to the motor nameplate for the motor parameters.

Parameter number	Parameter name	Parameter number	Parameter name
P1-01	Motor rated power	P1-04	Motor rated frequency
P1-02	Motor rated voltage	P1-05	Motor rated speed
P1-03	Motor rated current		

2. Use the operation panel to control the start and stop and set the operating frequency.

(1) Power-on. Use the operation panel to set motor parameters (P1-01 to P1-04) , running frequency (P1-08) and acceleration/deceleration time (P1-17, P1-18)

Parameter number	Parameter name	Parameter number	Parameter name
P0-02	Command Set Channel Selection	0 (factory default)	Run command channel as keyboard
P0-03	Frequency setting channel selection	0	The operating frequency is given by the keyboard number
P0-17	Acceleration time 1	-	Acceleration time, adjust according to actual needs
P0-18	Deceleration time 1	-	Deceleration time, adjust according to actual needs

(2) Press the key on the operation panel **RUN** to start the inverter, press ▲/▼key to increase/decrease the set frequency, and press the key **STOP** to stop the inverter output.

3. Use the terminal to control the start and stop and the keyboard potentiometer to set the operating frequency.

(1) Terminal DI1 is for forward rotation signal input, DI2 is for reverse rotation signal input, the wiring is as shown in the figure below.

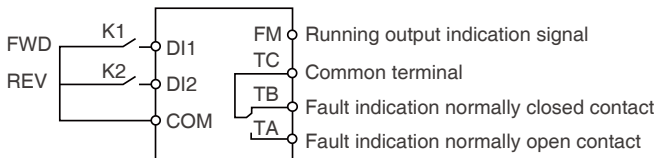

(2) Power on, and then set the function parameters according to the wiring diagram, see the table below.

Parameter number	Parameter name	Set value	Meaning
P0-02	Command Set Channel Selection	1	Run command channel as terminal
P0-03	Frequency setting channel selection	3 (factory value)	The operating frequency is given by the keyboard potentiometer
P0-17	Acceleration time 1	-	Acceleration time, adjust according to actual needs
P0-18	Deceleration time 1	-	Deceleration time, adjust according to actual needs
P4-00	DI1 terminal function	1 (factory default)	Forward rotation function (terminal forward rotation signal input)
P4-01	DI2 terminal function	1 (factory value)	Reverse function (terminal reverse signal input)

(3) When K1 in the wiring diagram is closed, the motor runs forward; when K1 is disconnected, the motor stops running. When K2 is closed, the motor runs in reverse; when K2 is disconnected, the motor stops running. When K1 and K2 are closed or disconnected at the same time, the motor will stop running. You can increase/decrease the set frequency by changing the size of the keyboard knob.

4. Use the terminal to control the start and stop and set the operating frequency by analog.

1. Terminal DI1 is for forward rotation signal input, DI2 is for reverse rotation signal input, the wiring is as shown in the figure below.

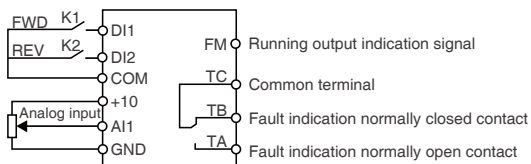

2. Power on, and then set the function parameters according to the wiring diagram, see the table below.

Parameter number	Parameter name	set value	Meaning
P0-02	Command set channel selection	1	Run command channel as terminal
P0-03	Frequency setting channel selection	2	The operating frequency is given by the AI1 external potentiometer
P0-17	Acceleration time 1	-	Acceleration time, adjust according to actual needs
P0-18	Deceleration time 1	-	Deceleration time, adjust according to actual needs
P4-00	DI1 terminal function	1 (factory default)	Forward rotation function (terminal forward rotation signal input)
P4-01	DI2 terminal function	2 (factory value)	Reverse function (terminal reverse signal input)

3. Set the operating frequency by adjusting the AI1 analog input.

4. When K1 in the wiring diagram is closed, the motor runs forward; when K1 is disconnected, the motor stops running. When K2 is closed, the motor runs in reverse; when K2 is disconnected, the motor stops running. When K1 and K2 are closed or disconnected at the same time, the motor will stop running.

5. Use the terminal to control the start and stop and communicate to set the operating frequency.

1. Terminal DI1 is for forward rotation signal input, DI2 is for reverse rotation signal input, the wiring is as shown in the figure below.

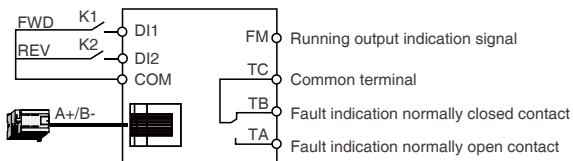

2. Power on, and then set the function parameters according to the wiring diagram, see the table below.

Parameter number	Parameter name	set value	Meaning
P0-02	Command Set Channel Selection	1	Run command channel as terminal
P0-03	Frequency setting channel selection	9	The operating frequency is given by communication
P0-17	Acceleration time 1	-	Acceleration time, adjust according to actual needs
P0-18	Deceleration time 1	-	Deceleration time, adjust according to actual needs
P4-00	DI1 terminal function	1 (factory default)	Forward rotation function (terminal forward rotation signal input)
P4-01	DI2 terminal function	2 (factory value)	Reverse function (terminal reverse signal input)

Parameter number	Parameter name	set value	Meaning
P5-00	FM terminal output mode	1	FMR switch output
P5-01	FM terminal function	1	Inverter running
PD-00	Baud rate	5(factory value)	9600bps
PD-01	Data Format	3(factory value)	8-N-1format,no parity, RTU
PD-02	Local address	1 (factory default)	

3. When K1 in the wiring diagram is closed, the motor runs forward; when K1 is disconnected, the motor stops running. When K2 is closed, the motor runs in reverse; when K2 is disconnected, the motor stops running. When K1 and K2 are closed or disconnected at the same time, the motor will stop running.

4. Write register 0 XF008H (P 0-08) through SCI communication function code 0x06 to modify the running frequencycode 0x06 to modify the running frequency.

6. Use the terminal to control the start and stop and the terminal UP / DOWN to control the operating frequency.

1. Terminal DI1 is the start/stop signal input, DI2 is the UP signal input, DI3 is the DOWN signal input, the wiring is as shown in the figure below.

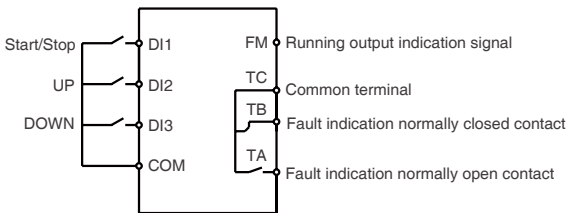

2. Power on, and then set the function parameters according to the wiring diagram, see the table below.

Parameter number	Parameter name	set value	Meaning
P0-02	Command set channel selection	1	Run command channel as terminal
P0-03	Frequency setting channel selection	1	Given by terminals UP and DOWN
P0-17	Acceleration time 1	-	Acceleration time, adjust according to actual needs
P0-18	Deceleration time 1	-	Deceleration time, adjust according to actual needs
P5-00	FM terminal output mode	1	FMR switch output
P5-01	FM terminal function	1	Inverter running

7. Use the terminal to control the multi-stage speed of the inverter

1. Terminal DI1 is start/stop signal input, DI2 is multi-stage speed signal 1 input, DI3 is multistage speed signal 2 input, DI4 is multi-stage speed signal 3, DI5 is multi-stage speed signal 4, the wiring is as shown in the figure below.

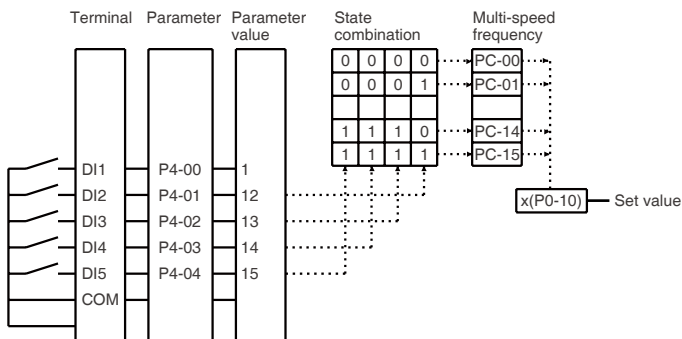

2. Power on , and then set the function parameters according to the wiring diagram, see the table below.

Parameter number	Parameter name	set value	Meaning
P0-02	Command set channel selection	1	Run command channel as terminal
P0-03	Frequency setting channel selection	6	The operating frequency is given by the multi-stage speed
P0-17	Acceleration time 1	-	Acceleration time, adjust according to actual needs
P0-18	Deceleration time 1	-	Deceleration time, adjust according to actual needs
P4-00	DI1 terminal function	1 (factory default)	Forward rotation function (terminal forward rotation signal input)
P4-01	DI2 terminal function	12 (factory value)	Multi-stage speed command terminal signal 1 input
P4-02	DI3 terminal function	13 (factory value)	Multi-stage speed command terminal signal 2 input
P4-03	DI4 terminal function	14 (factory value)	Multi-stage speed command terminal signal 3 input
P4-04	DI5 terminal function	15 (factory value)	Multi-stage speed command terminal signal 4 input
PC-00	multi-segment instruction 0	-	Adjust according to actual needs
PC-01	multi-segment instruction 1	-	Adjust according to actual needs
PC-02	multi-segment instruction 2	-	Adjust according to actual needs
PC-03	multi-segment instruction 3	-	Adjust according to actual needs
PC-04	multi-segment instruction 4-	-	Adjust according to actual needs

PC-05	multi-segment instruction 5	-	Adjust according to actual needs
PC-06	multi-segment instruction 6	-	Adjust according to actual needs
PC-07	multi-segment instruction 7	-	Adjust according to actual needs

8. Process PID application function control

1. Terminal DI1 is the start/stop signal input, AI1 is the PID analog feedback source input, the wiring is as shown in the figure below.

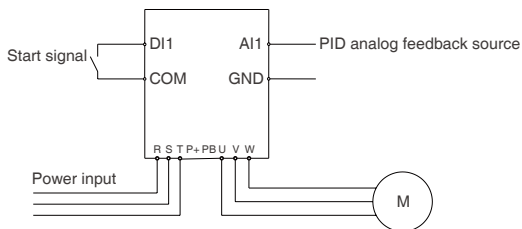

2. Power on, and then set the function parameters according to the wiring diagram, see the table below.

Parameter number	Parameter name	set value	Meaning
P0-02	Command Set Channel Selection	1	Run command channel as terminal
P0-03	Frequency setting channel selection	8	Given by the P ID
P0-17	Acceleration time 1	-	Acceleration time, adjust according to actual needs
P0-18	Deceleration time 1	-	Deceleration time, adjust according to actual needs
PA.00	PID given source	0 (factory value)	PID given source is set for PA -01

Parameter number	Parameter name	set value	Meaning
PA.01	PID value given	50% (factory value)	Adjust according to actual needs
PA.02	PID Feedback Source	0 (factory value)	Analog AI1 feedback input

9. Motor parameter adjustment and setting

1. Motor parameter tuning can only be performed in the operation panel control mode.

2. Wiring correctly.

3. Power on, set the motor parameters (P1-00 - P1-05) with the operation panel.

4. Parameter tuning, the tuning methods that can be used in different control modes are shown in the table below.

Control method	Self-tuning method (recommended)	
V/F control	Manual torque boost using static, rotating, stator resistance auto-tuning	Automatic torque boost using stationary, rotating autotune
Vector control	Use rotating autotune	

Static tuning of motor parameters:

P1-37 = 1 (static self-tuning) , press the button to **PRG** to the display state of the stop parameters, and press the button **RUN** to start the self-tuning.

After the auto-tuning is finished, P1-06 - P1-08 will be refreshed automatically.

Parameter number	Parameter name	Parameter number	Parameter name
P1-06	Motor stator resistance	P1-08	Motor leakage inductance
P1-07	Electronic rotor resistance		

Motor parameters rotary tuning:

Before performing rotary tuning, please disconnect the motor from the load.

Then set P1-37 = 2 (rotary tuning) , press the key **PRG** to return to the stop parameter display state, and press the key **RUN** to start the auto-tuning.

During the rotation of the motor, there may be vibration or even overcurrent. At this time, press the key **STOP** to stop the parameter setting, and adjust the acceleration and deceleration time properly to reduce the possible vibration.

After parameter tuning is completed, P1-06-P1-10 will be refreshed automatically.

Parameter number	Parameter name	Parameter number	Parameter name
P1-05	Rated speed of motor 1	P1-08	Motor 1 leakage inductance
P1-06	Motor 1 Stator Resistance	P1-09	Motor 1 Mutual Inductance Reactance
P1-07	Motor 1 rotor resistance	P1-10	Motor 1 no-load excitation current

1 Chapter 1 Safety Information and Precautions

1.1 Security definition

▲ Danger: Information marked as Danger is critical to avoid safety incidents.
▲ WARNING: Information marked as a WARNING is necessary to avoid damage to the product or other equipment
▲ CAUTION: Information marked as a CAUTION assists in the proper use of the product.

1.2 Motor and mechanical load related

Compared with power frequency operation

FC200 is a voltage type inverter, the output voltage is PWM wave, which contains certain harmonics. Therefore, the temperature rise, noise and vibration of the motor during use are slightly increased compared with power frequency operation.

Constant torque low speed operation

When the Frequency Inverter drives the ordinary motor to run at low speed for a long time, the output torque will decrease due to the deterioration of the heat dissipation effect of the motor. If it is in the long-term low-speed constant torque operation condition, it is recommended to choose a frequency conversion motor.

Electronic thermal protection of the motor

When selecting a suitable motor, the inverter can effectively implement thermal protection for the motor. If the power of the controlled motor does not match the inverter, you must adjust the motor protection parameters or other protection measures to ensure the safe and reliable operation of the motor.

Above the rated frequency of the motor

If the motor is operated above its rated frequency, the noise will increase. It is necessary to pay attention to the vibration of the motor, and at the same time to ensure that the motor bearings and mechanical devices can meet the requirements of the operating speed range.

Lubrication of mechanical devices

For long-term low-speed operation, mechanical devices such as gearboxes and gears should be regularly lubricated and maintained to ensure that the transmission effect can meet the needs of the site.

Mechanical resonance point

Avoid the mechanical resonance point of the load device or the motor by setting the jump frequency of the inverter (P8-09-P8-10) .

Motor Insulation Inspection

When the motor is used for the first time or after long-term storage, the motor insulation should be inspected to avoid damage to the inverter due to deterioration of the motor insulation.

Notice: Please use a 500V voltage type megohmmeter for the test, and the insulation resistance is not less than 5 megohms.

Negative torque load

For occasions such as lifting loads, negative torque often occurs, and the inverter often trips due to over-current or over-voltage faults . Braking components with appropriate parameters should be considered.

Leakage current protector RCD requirements

When the equipment is in operation, a large leakage current will flow through the protective grounding conductor. Please install a B-type leakage protector RCD on one side of the power supply. When selecting the RCD of the leakage protector, the transient and steady-state leakage current to the ground that may occur during the start-up and operation of the equipment should be considered, and a special RCD with measures to suppress high-order harmonics, or a general-purpose RCD with a large residual current should be selected.

Earth leakage warning

The device will generate a large leakage current during operation. Before connecting to the input power supply, please be sure to ground it reliably. The grounding of the equipment must comply with the relevant IEC standards of local regulations.

1.3 Inverter related

It is forbidden to install capacitors or pressure-sensitive devices to improve power factor on the output side

Since the output of the inverter is a PWM wave, it is strictly forbidden to install a capacitor for improving the power factor or a piezoresistor for lightning protection on the output side to avoid possible tripping of the inverter or damage to the device.

The output end is externally connected with switching devices such as contactors

If there are switching devices such as contactors installed between the inverter and the motor, please make sure that the inverter has no output and perform on-off operations, otherwise the inverter will be damaged.

Operating voltage

It is strictly forbidden to use directly outside the voltage range specified by FC200. If the power supply voltage is not suitable, the corresponding voltage regulating device should be used to transform the voltage to obtain a voltage that meets the product's use.

Capacitor energy storage

In the event that the AC power supply is cut off, the capacitors in the Frequency Inverter will remain charged for a period of time, and the voltage is enough to kill. If the inverter has been powered on before, you must cut off the AC power supply for more than 10 minutes, and confirm that the internal charging indicator light is off, and the voltage between the power terminals (+) and (-) is lower than 36V before disassembling the machine.

Normally, internal circuitry discharges the capacitor. However, under some abnormal conditions, the capacitor may not be able to discharge. In this case, please consult our company or distributors.

Three-phase input changed to single-phase input

For three-phase input inverter, users are advised not to change to single-phase input.

If single-phase power must be used, the input phase loss protection function should be cancelled. The bus voltage and current ripple will increase, resulting in poor performance of the inverter and shortened capacitor life; in this application, derating is required, not exceeding 60% of the rated value of the inverter.

Lightning impact protection

The inverter is designed with a lightning strike overcurrent protection circuit, which has a certain self-protection ability against induced lightning.

Altitude and derating

In areas where the altitude exceeds 1000 meters, the heat dissipation effect of FC200 will be deteriorated due to the thin air. At this time, FC200 must be used with derating.

Every time the altitude rises by 100m, the output current rating will be reduced by 1%. That is, the altitude rises to 4000m, and the inverter current rating is derated by 30%.

Figure 11-is the derating relationship curve between the rated current of the inverter and the altitude above sea level.

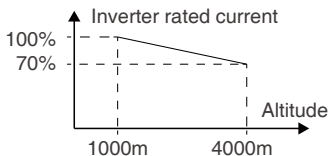
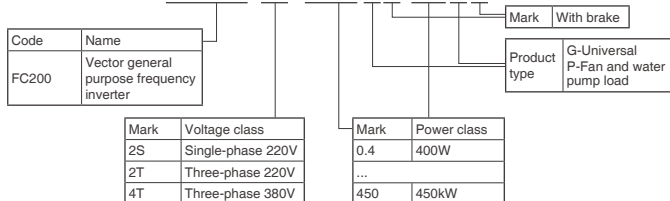

Figure 1-1 derating relationship curve

Chapter 2 Product Information

2.1 Model

FC200-4T-0.75GB/1.5PB



2.2 Nameplate

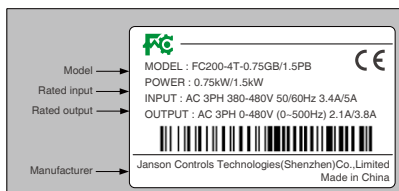

2.3 Rated value

For structural specifications, please refer to Section Dimensions and Installation Dimensions, page 26.

Model	Adapted motor (kW)	Rated input current (A)	Rated output current (A)	Rated capacity (kVA)	Structural specification
1/3 Phase Input and 3 Phase Output 220V (-15%~+15% Tolerance)					
FC200-2S-0.4GB	0.4	6.5	2.1	0.7	S1
FC200-2S-0.75GB	0.75	8.2	4.0	1.5	S1
FC200-2S-1.5GB	1.5	14	7	3	S1

FC200-2S-2.2GB	2.2	23	9.6	4	S1
FC200-2S-4.0GB	4	35	17	11	S3
FC200-2S-5.5GB	5.5	45	25	17	S4
FC200-2S-7.5GB	7.5	75	32	21	S4
FC200-2S-11G(B)	11	100	45	30	S5
FC200-2S-15G(B)	15	130	60	39	S5
3 Phase Input and 3 Phase Output 220V (-15%~+15% Tolerance)					
FC200-2T-18.5G(B)	18.5	77	75	57	S5
FC200-2T-22G(B)	22	92	90	69	S6
FC200-2T-30G(B)	30	113	110	85	S6
3 Phase Input and 3 Phase Output 380V (-15%~+15% Tolerance)					
FC200-4T-0.75GB/1.5PB	0.75/1.5	3.4/5	2.1/3.8	1.5/3	S1
FC200-4T-1.5GB/2.2PB	1.5/2.2	5/5.8	3.8/5.1	3/4	S1
FC200-4T-2.2GB/4.0PB	2.2/4	5.8/10.5	5.1/9	4/5.9	S1
FC200-4T-4.0GB/5.5PB	4/5.5	10.5/14.6	9/13	5.9/8.9	S2
FC200-4T-5.5GB/7.5PB	5.5/7.5	14.6/19	13/17	8.9/11	S2
FC200-4T-7.5GB/11PB	7.5/11	19/28	17/25	11/16	S2
FC200-4T-11GB/15PB	11/15	28/35	25/32	16/21	S3
FC200-4T-15GB/18.5PB	15/18.5	35/39	32/37	21/24	S3
FC200-4T-18.5GB/22PB	18.5/22	39/47	37/45	24/30	S4
FC200-4T-22GB/30PB	22/30	47/62	45/60	30/39	S4
FC200-4T-30G(B)/37P(B)	30/37	62/77	60/75	39/49	S5
FC200-4T-37G(B)	37	77	75	49	S5
FC200-4T-45G(B)/55P(B)	45/55	92/113	90/110	59/72	S6
FC200-4T-55G(B)	55	113	110	72	S6
FC200-4T-75G(B)/90P(B)	75/90	156/180	152/173	114/134	S7
FC200-4T-90G/110P	90/110	180/214	176/210	134/160	S8
FC200-4T-110G/132P	110/132	214/256	210/253	160/192	S8

Model	Adapted motor (kW)	Rated input current (A)	Rated output current (A)	Rated capacity (kVA)	Structural specification
FC200-4T-132G/160P	132/160	256/307	253/304	192/231	S9
FC200-4T-160G/185P	160/185	307/345	304/340	231/236	S9
FC200-4T-185G	185	345	340	236	S9
FC200-4T-200G/220P	200/220	385/430	377/426	250/280	S10
FC200-4T-220G/250P	220/250	430/468	426/465	280/355	S10
FC200-4T-250G/280P	250/280	468/525	465/520	355/396	S11
FC200-4T-280G/315P	280/315	525/590	520/585	396/445	S11
FC200-4T-315G/355P	315/355	590/665	585/650	445/500	S12
FC200-4T-355G/400P	355/400	665/785	650/725	500/565	S12
FC200-4T-400G/450P	400/450	785/883	725/800	565/630	S12
FC200-4T-450G	450	883	820	630	S12

2.4 Technical specifications

Electrical specifications	
Input Voltage	Single Phase/Three Phase 200~240V, Three Phase 380~440V Fluctuate no more than $\pm 10\%$, Imbalance Rate $< 3\%$
Input Frequency	50/60Hz $\pm 5\%$
Output Voltage	0V~Input Voltage
Output Frequency	Vector Control:0~300Hz V/F Control:0~500Hz
Performance	
Overload Capacity	150% rated output current for 1 minute, 180% rated output current for 2 seconds
Control Method	Open-loop vector control (SVC), V/F control
Run Command Setting Method	Operation Panel Setting, External Terminal Setting, Communication Setting
Speed Setting Method	Digital setting, analog setting/pulse setting, communication setting

Speed Setting Resolution	Digital setting: 0.01Hz, Analog setting: 1% × maximum frequency
Speed Control Accuracy	SVC: ±0.5%
Speed Control Range	SVC: 1:100
Torque Control Response	SVC: <200ms
Starting Torque	SVC: 150% rated torque/0.5Hz
Special feature	
Programmable Input & Output Terminals	Input& Output terminal function can be edited
Process PID Adjustment Function	Built-in process PID module
Simple PLC Function	Built-in simple PLC module, which can realize timing and multi-segment frequency output
Textile Wobble Function	Built-in textile swing frequency function module
Water Supply Function	Built-in constant pressure water supply parameter macro
Engraving Machine Function	Built-in engraving machine high frequency parameter macro
Fire Mode	Built-in European fire mode parameter set
Protective function	
Overvoltage Stall	Bus voltage automatic control to prevent overvoltage fault
Automatic Current Limiting Protection	Output current is automatically limited to prevent over-current faults
Overload Pre-Alarm & Alarm	Overload Pre-warning and protection
Output Phase Loss Protection	Output phase loss automatic detection and alarm function
Overvoltage & Overflow Stall Control	Automatically limit current and voltage during operation to prevent frequent over-current and over-voltage tripping
Output Short-to-Ground Protection	Effective protection function for output short circuit to ground
Output Phase-to-Phase Short Circuit Protection	Output interphase short circuit effective protection function
Input & output	
External analog power supply	+10V-GND

External digital power supply	24V-COM
Analog Input	AI1:Voltage 0~10V/0-20mA AI2:Voltage 0~10V/0-20mA
Analog Output	AO1:0~10V/0~20mA(Voltage/Current Optional) AO2:0~10V/0~20mA(Voltage/Current Optional)
Digital Input	DI1~DI5(can be selected as a high-speed pulse signal)
Digital Output	FM,AO2,FM can be selected as high-frequency pulse signal output
Relay output	TA/TB/TC:Contact rating 250VAC/3A or 30VDC/1A
MODBUS Communication	A+、B-
Operation display	
LED Display	Set frequency, output frequency, output voltage, output current, motor speed, Output torque, digital terminals, status parameters, programming menu parameters and fault codes etc
Indicator Light	3 unit indicators, 4 status indicators
Environmental characteristics	
Working Temperature	-10~+40°C , Maximum temperature is 50°C, Air Temperature change is less than 0.5°C/min,40~50°C Derating is required, output current derating 2% for each 1°C
Storage Environment Temperature	-40~+70°C
Application	Indoor, free from direct sunlight, dust, corrosive gas, flammable gas, oil mist, water vapor, dripping water or salt etc.
Altitude	Less than 1000 meters, derating is required for more than 1000 meters
Humidity	Less than 95%RH, no condensation
Vibration Resistance	3.5m/s ² at 2-9Hz, 10m/s ² at 9-200Hz (IEC60721-3-3)
Protection Degree	IP20
Pollution Level	Class 2 (dry, non-conductive dust pollution)
Certification	
CE	The whole series has passed CE certification

Chapter 3 Mechanical Installation

3.1 Installation precautions

Danger

- If the parts of the inverter are incomplete or damaged, please do not install it.
- During transportation, please use appropriate tools according to the weight of the inverter to avoid being cut by sharp corners or being injured when the inverter rolls over or falls.
 - The inverter should be installed on flame-retardant objects such as metals, away from flammable and explosive objects.
 - After the inverter is reliably powered off for 10 minutes, make sure that the internal charging indicator light is off and the voltage between the power terminals (+) and (-) is lower than 36V before operating.

Warn

- When transporting, please hold the bottom of the inverter instead of just the operation panel and cover.
- During installation work, do not drop wires, screws, and drilling residues into the inverter.

3.2 Installation site requirements

Confirm that the installation site meets the following conditions:

- Avoid installing in places exposed to direct sunlight, humidity, and drops of water;
- Avoid installing in places with flammable, explosive and corrosive gases and liquids;
- Avoid installing in places with oily dust, fibers and metal particles;
- Install vertically on an object that is flame retardant and can bear the weight of the fuselage;
- There is enough heat dissipation space around the inverter to ensure that the ambient temperature is within $-10\text{--}+40^{\circ}\text{C}$;
- The installation foundation is solid, meeting the product vibration requirements, 3.5m/s^2 at 2-9Hz, 10m/s^2 at 9-200Hz (IEC60721-3-3);

- Installed in a place where the humidity is less than 95%RH and there is no condensation of water droplets;
- The protection level of the frequency inverter is IP20, and the pollution level is level 2 (dry, non-conductive dust pollution).

Notice:

1. If the operating environment of the inverter exceeds 40°C, derating is required. For every increase of 1°C, the inverter needs to be derated by 2%. The maximum working ambient temperature is 50 °C.

2. Keep the ambient temperature -10-+40°C, install it in a well-ventilated place or add a cooling device, which can improve the reliability of the inverter operation.

3.3 Installation direction and space

In order to make the inverter have a good heat dissipation effect, the inverter must be installed vertically, and there must be enough space between the top, bottom, left, and right sides and adjacent objects or baffles (such as walls). The installation space dimensions are shown in Table 3-1.

Table 3-1 Inverter Installation Space Dimensions table

Inverter class	≤ 15 kW	≥ 18.5 kW < 55kW	≥ 75kW
A (left and right)	≥ 10mm	≥ 30 mm	≥ 150mm
B (up and down)	≥ 100mm	≥ 100mm	≥ 350mm
C (upper vent)	≥ 50mm	≥ 50mm	≥ 100mm
D (lower vent)	≥ 50mm	≥ 50mm	≥ 100mm

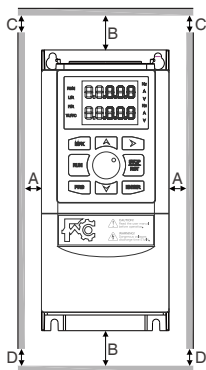

When multiple frequency inverter are installed up and down, there should be a flow guide partition in the middle, and the installation space size is shown in Table 3-2 .

Table 3-2 Multiple frequency inverter installation space dimensions

Inverter class	$\leq 15\text{kW}$	$\geq 18.5\text{kW}$, $< 55\text{kW}$	$\geq 75\text{kW}$
A	$\geq 10\text{mm}$	$\geq 50\text{mm}$	$\geq 100\text{mm}$
B	$\geq 30\text{mm}$	$\geq 50\text{mm}$	$\geq 100\text{mm}$
C	$\geq 30\text{mm}$	$\geq 50\text{mm}$	$\geq 100\text{mm}$
a	$\geq 10\text{mm}$	$\geq 50\text{mm}$	$\geq 100\text{mm}$
b	$\geq 30\text{mm}$	$\geq 50\text{mm}$	$\geq 100\text{mm}$
c	$\geq 30\text{mm}$	$\geq 50\text{mm}$	$\geq 100\text{mm}$

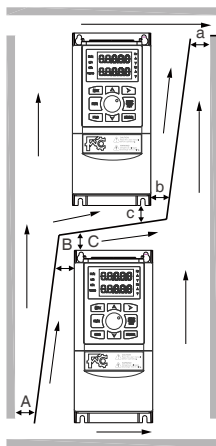

3.4 Outlook dimensions and Installation dimensions

FC200 appearance and installation dimensions are shown in Table 3-3 .

For specific models corresponding to external dimensions, see Section Section 2.3 Rated value,page 17 .

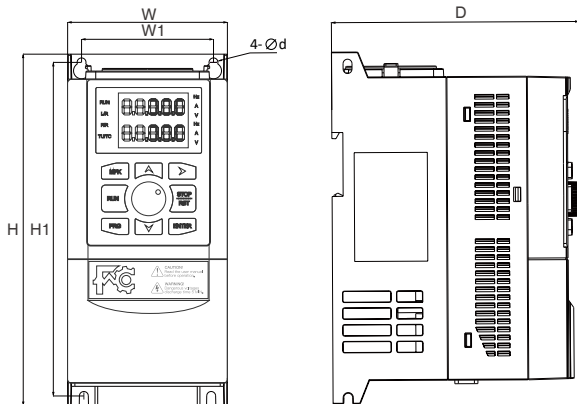

S1 outline drawing

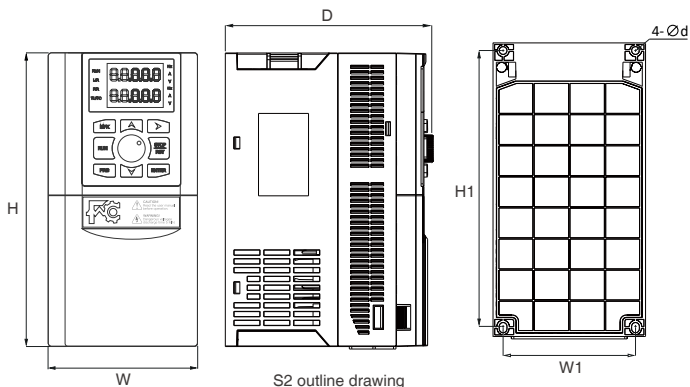

S2 outline drawing

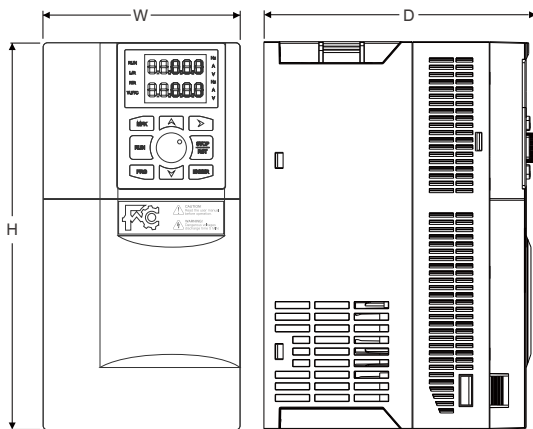

S3 outline drawing

Structural specification	Power range	Dimensions (mm)			Installation size (mm)		
		W	H	D	W1	H1	d
S1	0.75~4.0kW	89.6	197.2	139	74	187	5
S2	5.5~7.5kW	102	202	162	90	189.1	5.6
S3	11~15kW	125	242.5	169.5	108.5	226	6.3
S4	18.5~22kW	165	297	206.2	147	278.5	7
S5	30~37kW	225	360	231.7	206	342	7
S6	45~55kW	260	440	240	220	420	8
S7	75kW	300	555	280	240	535	10
S8	90~110kW	338	580	325	270	560	10
S9	132~185kW	400	780	350	320	756	10
S10	200~220kW	520	780	355	380	756	12
S11	250~280kW	620	880	370	480	848	14
S12	315~450kW	780	1350	394	620	1320	14

Chapter 4 Electrical Installation

4.1 Wiring precautions

Danger

- Wiring must be performed by qualified electrical engineers.
- In order to provide over-current protection on the input side and facilitate power failure maintenance, the Frequency Inverter should be connected to the power supply through an air switch MCCB or a fuse.
 - After the inverter is reliably powered off for 10 minutes, and after confirming that the internal charging indicator light is off and the voltage between the power terminals (+) and (-) is lower than 36V, then wiring or disassembly of the internal components of the inverter can be performed.
 - After the emergency stop terminal of the external power supply is connected, it must be confirmed that its action is effective and reliable.
 - The inverter has a leakage current greater than 3mA to the ground. The specific value is determined by the use conditions. To ensure safety, the inverter and the motor must use two independent grounding wires to ensure reliable grounding. It is recommended that the user install a Type B leakage protection device (ELCB/RCD).
 - When the inverter is charged, the human body should not touch the inverter terminal. Do not connect the power terminals of the inverter to the product casing, and do not short-circuit between the power terminals.

Warn

- The inverter has passed the withstand voltage test before leaving the factory, and the user can no longer conduct the withstand voltage test on the inverter.
- For inverter that have been stored for more than 2 years, when powered on, the voltage regulator should be slowly boosted to supply power.
 - When an external braking resistor is required, please connect the braking resistor or braking unit according to the wiring diagram.
 - Please securely fasten the terminals.
 - It is forbidden to connect the input power line to the output U/V/W terminal.
 - It is forbidden to connect the phase-shifting capacitor to the output circuit.
 - The motor can be switched or frequency conversion/power frequency switching can only be performed when the Frequency Inverter stops outputting.
 - It is forbidden to short-circuit the DC bus terminals of the inverter.

4.2 Peripheral device selection

4.2.1 Input and output wiring specifications

Between the power supply and the frequency inverter, a breaking device such as an air switch (MCCB) or a fuse with overcurrent protection must be installed to avoid the expansion of the impact range caused by the failure of the subsequent equipment to ensure equipment and personal safety.

The recommended values of the recommended air switch MCCB, contactor capacity and cross-sectional area of copper core insulated conductors are shown in Table 4-2 .

Sectional area of the grounding protective conductor (grounding wire) should meet the requirements of 4.3.5.4 of IEC61800-5-1, as shown in Table 4-1.

Table 4-1 Cross-sectional area of grounding protective conductor

The cross-sectional area S (mm ²) of the phase conductor (power line) during installation	$S \leq 2.5$	$2.5 < S \leq 16$	$16 < S \leq 35$	$S > 35$
The minimum cross-sectional area S_p (mm ²) of the corresponding protective conductor (grounding wire)	2.5	S	16	$S/2$

Table 4-2 Input and output wiring selection

Model	MCCB (A)	Contactor (A)	Power cord (mm ²)	Motor wire (mm ²)	Ground wire (mm ²)	Structural specification
1/3 Phase Input and 3 Phase Output 220V (-15%~+15% Tolerance)						
FC200-2S-0.4GB	16	10	0.5	0.5	2.5	S1
FC200-2S-0.75GB	16	10	0.75	0.5	2.5	S1
FC200-2S-1.5GB	20	16	4	0.8	4	S1
FC200-2S-2.2GB	32	20	6	1.5	6	S1
FC200-2S-4.0GB	100/40(1)	63/32(1)	10/4(1)	4	10/4(1)	S3
FC200-2S-5.5GB	125/63(1)	100/40(1)	25/6(1)	6	16/6(1)	S4
FC200-2S-7.5GB	160/63(1)	100/40(1)	25/10(1)	10	16/10(1)	S4

Model	MCCB (A)	Contactora (A)	Power cord (mm ²)	Motor wire (mm ²)	Ground wire (mm ²)	Structural specification
FC200-2S-11G(B)	200/100 ⁽¹⁾	125/63 ⁽¹⁾	25/16 ⁽¹⁾	16	16	S5
FC200-2S-15G(B)	200/125 ⁽¹⁾	160/100 ⁽¹⁾	50/25 ⁽¹⁾	16	25/16 ⁽¹⁾	S6
3 Phase Input and 3 Phase Output 220V (-15%~+15% Tolerance)						
FC200-2T-18.5G(B)	160	100	25	25	16	S5
FC200-2T-22G(B)	200	125	35	35	16	S5
FC200-2T-30G(B)	200	125	35	35	16	S6
3 Phase Input and 3 Phase Output 380V (-15%~+15% Tolerance)						
FC200-4T-0.75GB/1.5PB	10	10	0.5	0.5	2.5	S1
FC200-4T-1.5GB/2.2PB	16	10	0.75	0.5	2.5	S1
FC200-4T-2.2GB/4.0PB	16	10	1.5	0.75	2.5	S1
FC200-4T-4.0GB/5.5PB	25	16	2.5	2.5	2.5	S2
FC200-4T-5.5GB/7.5PB	32	25	4	4	4	S2
FC200-4T-7.5GB/11PB	40	32	6	6	6	S2
FC200-4T-11GB/15PB	63	40	10	10	10	S3
FC200-4T-15GB/18.5PB	63	40	10	10	10	S3
FC200-4T-18.5GB/22PB	100	63	16	16	16	S4
FC200-4T-22GB/30PB	100	63	25	25	16	S4
FC200-4T-30G(B)/37P(B)	125	100	25	25	16	S5
FC200-4T-37G(B)	160	100	35	35	16	S5
FC200-4T-45G(B)/55P(B)	200	125	35	35	16	S6
FC200-4T-55G(B)	200	125	50	50	25	S6
FC200-4T-75G(B)/90P(B)	250	160	50	50	25	S7
FC200-4T-90G/110P	250	160	95	70	50	S8
FC200-4T-110G/132P	350	350	120	120	60	S8
FC200-4T-132G/160P	400	400	120	120	60	S9
FC200-4T-160G/185P	500	400	185	185	95	S9

FC200-4T-185G	500	410	185	185	95	S9
FC200-4T-200G/220P	600	600	240	240	120	S10
FC200-4T-220G/250P	600	600	120*2 ⁽¹⁾	120*2 ⁽¹⁾	120	S10
FC200-4T-250G/280P	800	600	150*2 ⁽¹⁾	120*2 ⁽¹⁾	120	S11
FC200-4T-280G/315P	800	800	185*2 ⁽¹⁾	185*2 ⁽¹⁾	150	S11
FC200-4T-315G/355P	800	800	240*2 ⁽¹⁾	240*2 ⁽¹⁾	185	S12
FC200-4T-355G/400P	800	800	240*2 ⁽¹⁾	240*2 ⁽¹⁾	240	S12
FC200-4T-400G/450P	1000	1000	240*2 ⁽¹⁾	240*2 ⁽¹⁾	240	S12
FC200-4T-450G	1000	1000	240*2 ⁽¹⁾	240*2 ⁽¹⁾	240	S12

4.2.2 Power terminal lugs

Wire lug of the power terminal can be selected according to the terminal wiring specification, screw specification, and the maximum outer diameter of the wire lug, see Table 4 -3 .

Round bare terminal as an example for wire lugs .

Table 4-3 Selection of wire lugs for power terminals

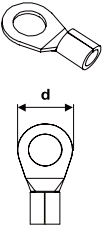
Inverter structure specification	Power range	Screw specification	Tightening torque (N.M)	The maximum outer diameter of the wire lug is allowed (mm)	
S1	0.75~4.0kW	M3.5	0.8~1.2	7	
S2	5.5~7.5kW	M4	1.2~1.5	9.9	
S3-S4	11~22kW	M5	2.5-3.0	12	
S5-S6	30~55kW	M6	4.0~5.0	15.5	
S7	75kW	M8	9.0~10.0	24	
S8	90~110kW	M10	17.6~22.5	30	
S9	132~185kW	M12	31.4~39.2	37	

Inverter structure specification	Power range	Screw specification	Tightening torque (N.M)	The maximum outer diameter of the wire lug is allowed (mm)	
S10	200~220kW	M12	31.4~39.2	40	
S11	250~280kW	M12	31.4~39.2	40	
S12	315~450kW	M16	48.6~59.4	40	

4.3 Control panel description

Danger

- The control circuit and the power circuit are basically insulated, and the inverter cannot be touched after it is powered on.

Warn

- If the control circuit is connected to an external device with an accessible port during power-on, it should be noted that an additional insulation protection isolation device should be added to ensure that the original voltage level of the external device will not be changed.
- If the communication terminal of the control circuit is used in connection with a PC, an RS485/232 isolation converter that meets the requirements of safety regulations should be selected.
- It is strictly forbidden to connect control terminals other than relay terminals to AC 220V voltage.

4.3.1 Jumper

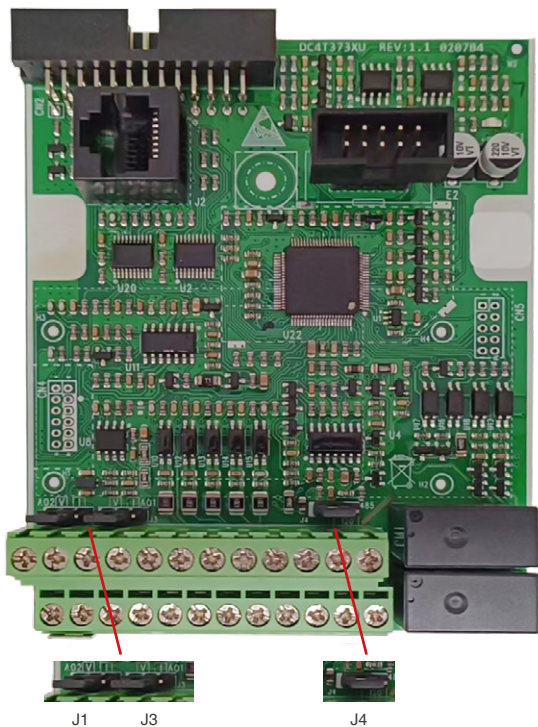

Figure 4-1 Jumper position (0.4–37kW)

4.3.2 Jumper description

Table 4-3 Jumper description(0.4~37kW)







Jumper	Jumper description
J4 	485 communication matching resistor selection: When pins 1 and 2 are short-circuited, the matching resistor is not used (factory setting); When pins 2 and 3 are short-circuited, use matching resistors.
J1 	AO2 analog voltage output and open collector output selection: When 1,2pins are shorted, AO2 is an open-collector output; when 2,3pins are shorted, AO2 is an analog output (factory setting).
J3 	AO1 analog output voltage/current selection: When 1,2pins are shorted, AO1 output is voltage (factory setting); when 2,3pins are shorted, AO1 output is current.

Table 4-4 Jumper description (45~500kW)

Jumper	Jumper description
J2 	485 communication matching resistor selection: When pins 1 and 2 are short-circuited, the matching resistor is not used (factory setting); When pins 2 and 3 are short-circuited, use matching resistors.
J3 	AO1 analog output voltage/current selection: When pins 2 and 3 are short-circuited, the output of AO1 is the current amount; When pins 1 and 2 are short-circuited, AO1 output is voltage (factory setting).
J4 	AO2 analog voltage output and open collector output selection: When pins 1 and 2 are short-circuited, AO2 is an open-collector output; When pins 2 and 3 are short-circuited, AO2 is analog output (factory setting).

4.3.3 Control terminal

A+	B-	GND	AI1	AI2	10V	AO1	AO2	DO1	RA	RB	RC
24V	OP	COM	DI1	DI2	DI3	DI4	DI5	FM	TA	TB	TC

Figure 4-5 Control Terminals(0.4~37kW)

A+	B-	GND	GND	AI1	AI2	10V	AO1	AO2	DO1	RA	RB	RC
24V	OP	COM	COM	DI1	DI2	DI3	DI4	DI5	FM	TA	TB	TC

Figure 4-6 Control Terminals(45~400kW)

Table 4-7 Control Terminal Description

Category	Terminal symbol	Terminal name	Function Description
Power supply	10V , GND	External + 10V power supply	+10V reference power supply for analog input, the maximum allowable output current is 100mA GND and COM isolation
	24V , COM	External + 24V power supply	+24V power supply for digital input, the maximum allowable output current is 200mA

Category	Terminal symbol	Terminal name	Function Description
Analog input	AI1 - GND	Analog input terminal 1	AI1 input voltage range : 0-10V , input impedance 32 K Ω AI1 input current range : 0-20mA , input impedance 500 Ω <ul style="list-style-type: none"> AI1 input voltage/current is optional: determined by P4-37 bits Input impedance: 22k Ω for voltage input, 500 Ω for current input
	AI2 -GND	Analog input terminal 2	AI 2 input voltage range : 0-10V , input impedance 32 K Ω AI2 input current range : 0-20mA , input impedance 500 Ω <ul style="list-style-type: none"> AI2 input voltage/current is optional: determined by the tens of P4-37 tens Input impedance: 22kΩ for voltage input, 500Ω for current input
Analog output	AO1-GND	Analog output 1	Output voltage/current signal: 0-10V/0-20mA <ul style="list-style-type: none"> Output current range: 0mA~20mA, 4~20mA (P5-23 optional) Voltage or current output is determined by the J3 jumper selection on the control board
	AO2- GND	Analog output 2	Output voltage signal: 0-10V <ul style="list-style-type: none"> voltage output is determined by the J1 jumper selection on the control board(Below 45kW) voltage output is determined by the J4 jumper selection on the control board(45kW and above)
Digital input	DI1-COM	Digital input 1	<ul style="list-style-type: none"> Optocoupler isolation, programmable bipolar selectable input signal Input voltage range : 5-30V DC DI1-DI4 input impedance 1kΩ
	DI2-COM	Digital input 2	
	DI3-COM	Digital input 3	
	DI4-COM	Digital input 4	
	DI5-COM	High-speed pulse input terminal	In addition to the characteristics of DI1-DI4,it can also be used as a high-speed pulse input channel. Maximum input frequency : 50kHz

Digital Output	DO1 - COM	Digital output	Optocoupler isolation, unipolar open collector output Output voltage range : 0-30 VDC Output current range : 0-50mA • Voltage output is determined by the J4 jumper selection on the control board (45kW and above)
	FM - COM	High speed pulse output	• Constrained by function code P5-00 "FM terminal output mode selection" • When used as a high-speed pulse output, the highest frequency is 50kHz; • When used as an open-collector output, it is the same specification as DO1-COM.
Relay output	TA-TB	Normally closed terminal	Programmable output, contact capacity: 250VAC/3A or 30VDC/1A
	TA-TC	Normally open terminal	
	RA-RB	Normally closed terminal	Programmable output, contact capacity: 250VAC/3A or 30VDC/1A
	RA-RC	Normally open terminal	

Note: If the relay terminal is connected to an AC 220V voltage signal, the current must be limited within 3A.

In order to reduce the interference to the control signal and the attenuation of the signal itself, the length of the control cable should be limited within 50m, and the distance between the control cable and the motor cable should be greater than 0.3m.

Control cables must be shielded cables, and analog signal cables use twisted-pair shielded wires.

4.3.4 Inverter application wiring mode

Three-phase 380V-440V
Input power 50/60HZ

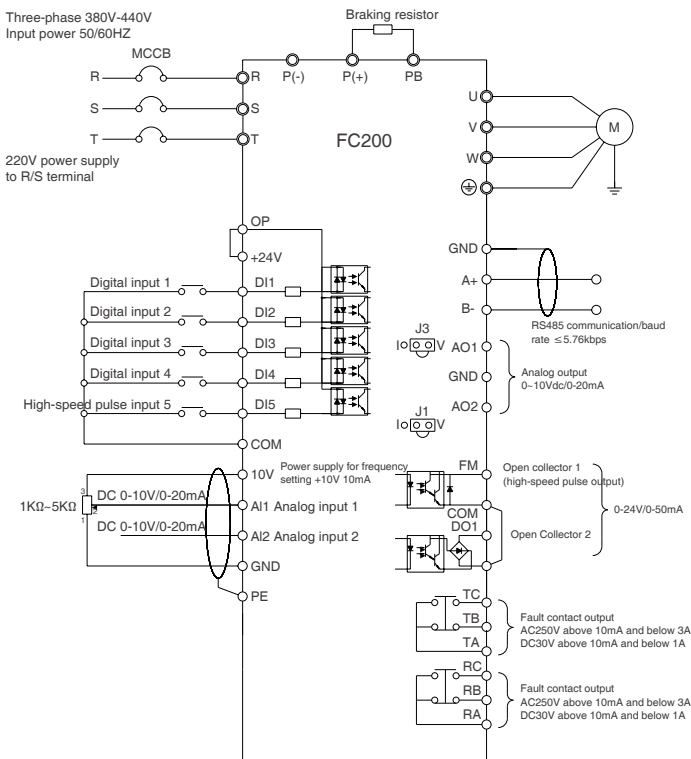

Figure 4-8 FC200 control terminal wiring diagram

Digital input terminal (DI) wiring

Source (drain) method

When using the internal 24V power supply of the inverter, the external controller is NPN type, PNP type common emitter output wiring mode, as shown in Figure 4-9.

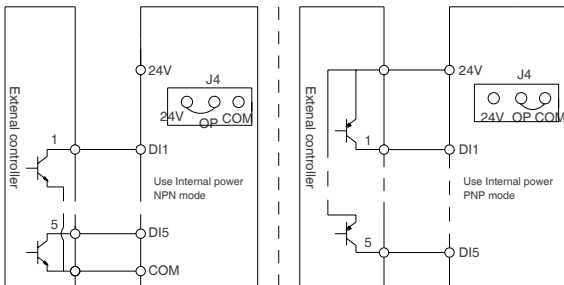

Figure 4-9 DI terminal input wiring when using internal 24V power supply

Analog input terminal (AI) wiring

AI1/AI2 can be selected as voltage input, the input range is 0-10V, the wiring is shown in Figure 4-10.

AI1/AI2 can be selected as current input, the input range is 0-20mA, the wiring is shown in Figure 4-10.

The wiring diagram of AI2 is the same as that of AI1 .

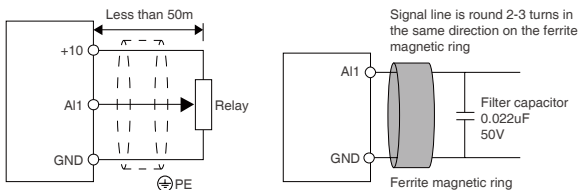

Figure 4-10 AI1 terminal wiring

Note:

In order to reduce the interference and attenuation of the control signal, the length of the control cable should be limited within 50m, and the shielding layer should be reliably grounded.

In the case of serious interference, the analog input signal needs to add filter capacitors or ferrite magnetic rings, as shown in Figure 4-10 .

Digital output terminal (FM) wiring

FM is an open-circuit collector output, which can use the internal 24V power supply of the inverter or use an external power supply. The wiring is shown in Figure 4-11 .

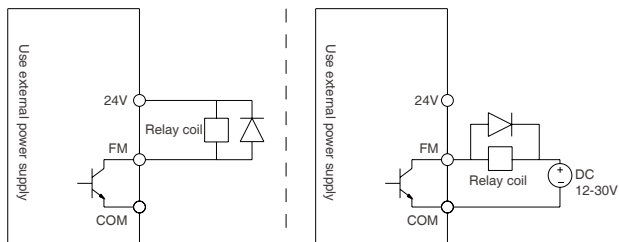

Figure 4-11 FM terminal wiring

The wiring of DO1 is the same as FM, as shown in Figure 4-11 .

FM is selected as the pulse frequency output, and the internal 24V power supply or external power supply of the inverter can be used. The wiring is shown in Figure 4-12.

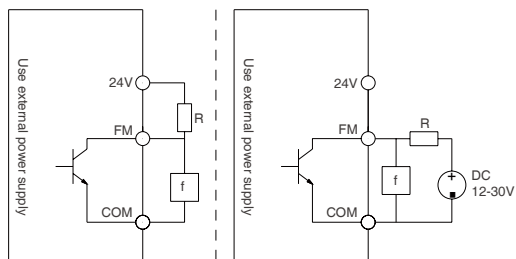

Figure 4-12 FM terminal wiring

4.4 Installation instructions for compliance with EMC requirements

4.4.1 Correct EMC installation

The national standard GB/T12668.3 stipulates that the inverter needs to meet the requirements of electromagnetic interference and anti-electromagnetic interference. The international standard IEC/61800-3 (the third part of variable frequency speed regulation drive system: EMC specification requirements and test methods) is equivalent to the national standard GB/T12668.3.

The FC200 produced by Janson Controls Technologies (Shenzhen) Co., Limited has been designed and tested according to the requirements of IEC/61800-3. Please follow the instructions in this section for correct EMC installation to make it have good electromagnetic compatibility.

- In the transmission system composed of the inverter and the motor, the inverter, the control device, and the sensor are installed in a cabinet, and the noise emitted to the outside must be limited at the main connection point, so EMI filters and AC reactors must be installed in the cabinet to meet the electromagnetic compatibility requirements.

- Considering the spatial separation of noise sources and noise receivers during the mechanical / system design phase is the most effective measure to reduce interference, but it is also the most expensive. In the transmission system composed of the inverter and the motor, the inverter, braking unit, contactor, etc. can all be noise sources, and the noise receivers can be automation devices, encoders, sensors, etc.

Machinery / system is divided into different EMC areas according to the electrical characteristics, and it is recommended to place the device in the areas divided as shown in Figure 4-13.

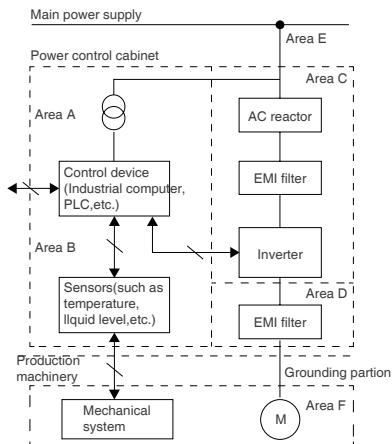

Figure 4-13 system-wiring area division diagram

Area A: control power transformer, control device, sensor, etc.

Area B: The signal and control cable interface part requires a certain degree of immunity.

Area C: Noise sources such as AC reactors, frequency Inverter, braking units, contactors, etc.

Area D: output EMI filter and its wiring part.

Area E: Power

Area F: Motors and its cables.

Description:

- The zones should be spatially separated to allow electromagnetic decoupling .
- minimum distance between each area is 20cm , and it is better to decouple with grounding partitions . The cables in different areas should be placed in different cable ducts.
- EMI filters should be installed at the interface between areas.
- All communication cables and signal cables leading out of the cabinet must be shielded.

4.4.2 Wiring requirements

In order to avoid mutual coupling of interference, the power cable, motor cable and control cable must be installed separately, and a sufficient distance must be ensured, especially when the cables are installed in parallel and extend for a long distance.

If the signal cable must pass through the power cable or motor cable, it must pass through vertically (the included angle is 90°), as shown in Figure 4-14.

Power cables, motor cables and control cables should be distributed in different conduits.

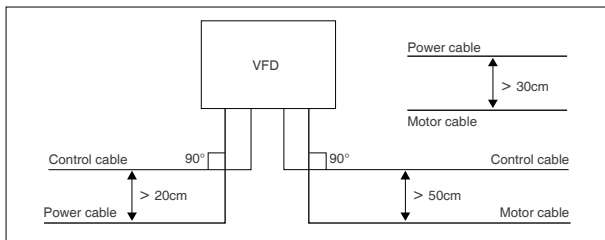

Figure 4-14 system-wiring area division diagram

Shielded / armored cables should be high-frequency low-impedance shielded cables. Such as braided copper wire mesh, aluminum wire mesh or barbed wire mesh, etc.

Generally, the control cable must be a shielded cable, and the shielded wire mesh must be connected to the metal casing of the inverter through the cable clips at both ends, as shown in Figure 4 -15 .

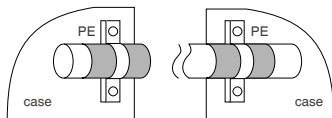

Figure 4 -15 shielded cable connection diagram

4.4.3 Motor wiring

The longer the motor cable and the higher the carrier frequency, the greater the high-order harmonic leakage current on the cable. Leakage current will have adverse effects on the equipment near the inverter.

When the motor cable exceeds 100 meters, it is recommended to install an AC output reactor, and refer to Table 4 and -6 to set the carrier frequency.

Table January 1911 Wiring distance and carrier frequency between 46 inverter motors

Wiring distance between inverter and motor	<30m	30-50m	50-100m	≥ 100m
Set carrier frequency	Below 15kHz	Below 10kHz	Below 5kHz	Below 2kHz

The motor cable should use the cable with the specified area, see Section Selection of Peripheral Components, page 28.

When the motor cable is too long or the cross-sectional area is too large, it must be used with derating. According to the recommended cross-sectional area, the current will be reduced by about 5% for each increase of one gear.

Because the larger the cross-sectional area of the cable, the greater the capacitance to ground, and the greater the leakage current to ground.

4.4.4 Grounding

The inverter has leakage current to the ground. The grounding terminal PE must be grounded as close as possible to the grounding point, the grounding area should be as large as possible, and the grounding resistance should be less than 10Ω .

Do not share the grounding wire (A) with other power equipment, you can share the grounding electrode (C), but each has a dedicated grounding electrode (B) for the best effect, as shown in Figure 4-16.

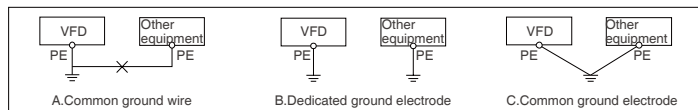

Figure 4-16 recommended grounding method

At the same time, when two or more inverter are used, please do not form a loop with the ground wire, as shown in Figure 4-17.

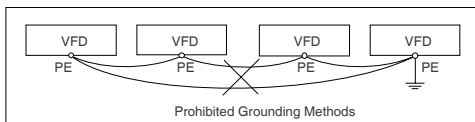

Figure 4-17 Prohibited grounding methods

4.4.5 EMI filter

Equipment that can generate strong interference and equipment that is sensitive to external interference should use EMI filters. EMI filters are bidirectional low-pass filters that allow low-frequency currents to pass through, but high-frequency electromagnetic interference currents are not easy to pass through.

The function of EMI filters

1. It enables the equipment to meet the requirements of the electromagnetic compatibility standard for conducted emission and conduction sensitivity, and can suppress the radiated emission of the equipment.
2. Prevent the electromagnetic interference generated by the device itself from entering the power line, and prevent the interference on the power line from entering the device.

Common mistakes in EMI filter installation

1. The wiring between the EMI filter and the inverter is too long.

The installation position of the filter in the cabinet should be close to the entrance of the power cable, and the power input cable of the filter should be as short as possible in the cabinet.

2. The input and output lines of the EMI filter are too close together.

The input and output lines of the filter are too close, and the high-frequency interference signal is directly coupled through the input and output lines of the filter, bypassing the filter, thus making the power line filter useless.

3. The EMI filter is poorly grounded.

The shell of the EMI filter must be reliably connected to the metal box. The shell of the filter usually has a dedicated ground terminal, but connecting the filter to the shell with a wire is useless for high-frequency interference signals, because the impedance (non-resistance) of the long wire is very large at high frequencies, there is no effective bypass effect at all.

Correct installation method : paste the EMI filter shell directly on the conductive plane of the metal casing of the equipment, and pay attention to remove the insulating paint.

4

4.4.6 Conducted, radiated, radio frequency interference countermeasures

Frequency Inverter Radiated Emissions

The working principle of the Frequency Inverter determines that the radiation emission of the Frequency Inverter is inevitable. The Frequency Inverter is generally installed in a metal cabinet, and the equipment outside the metal cabinet is less affected by the radiation emission of the Frequency Inverter itself. The external connection cable is the main source of radiation emission. Wiring according to the cable requirements described in this section can effectively suppress the radiation emission of the cable.

If the Frequency Inverter and other control devices are in the same metal cabinet, careful consideration should be made when designing the cabinet according to the aforementioned partition principles, and attention should be paid to the isolation of each section, cable wiring, shielding and lapping.

Conducted disturbance countermeasures

To suppress the conduction interference that occurs on the output side, in addition to installing a noise filter, you can also use the method of leading the output wiring into a grounded metal pipe. The distance between the output wiring and the signal line is greater than 0.3 m, and the influence of conducted interference is also significantly reduced.

Radio Frequency Interference Countermeasures

The input connection, output connection and the Frequency Inverter itself will generate radio frequency interference. EMI filters are installed on both sides of the input and output, and shielded with iron vessels, which can reduce radio frequency interference. The connection between the inverter and the motor should be as short as possible. Measures to mitigate radio frequency interference are shown in Figure 4-18

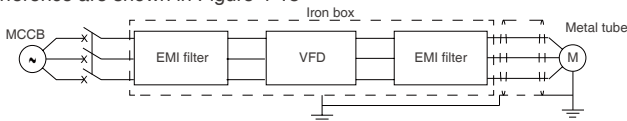

Figure 4-13 Radio Frequency Interference Measures

4.4.7 Reactor

AC input reactor

The purpose of configuring the AC line reactor is to: improve the power factor of the input side;effectively eliminate the high-order harmonics on the input side, prevent other equipment from being damaged due to voltage waveform distortion; eliminate the input current imbalance caused by the imbalance between phases of the power supply.

DC reactor

If the inverter is equipped with a DC reactor, it can improve the power factor of the input side,improve the efficiency and thermal stability of the inverter, effectively eliminate the impact of highorder harmonics on the input side on the inverter, and reduce external conduction and radiationinterference.

AC output reactor

distance between the motor and the inverter exceeds 100 meters, a large leakage current will be generated, causing the inverter to be protected. At this time, it is recommended to install an output AC reactor.

Chapter 5 Operation

Danger

- The inverter can only be powered on after the chassis shell is installed. It is strictly forbidden to disassemble the case shell after power on.
- Before the inverter starts the motor and mechanical equipment, please make sure that the motor and mechanical equipment are working within the allowable range of use.
 - If the Frequency Inverter has been set with an undervoltage restart function, please do not approach the mechanical transmission equipment.
 - If the main control board is replaced, the parameters must be set correctly after replacement before it can run.

Warn

- It is forbidden to check and measure the signal while the inverter is running.
- Do not change the parameter settings of the inverter at will.
- Before switching the inverter running command channel, be sure to perform switching debugging.
- The energy consumption braking resistor is very hot, please do not touch it.

5.1 Explain

5.1.1 Run command channel

The physical channel for FC200 to receive running commands (start, run, stop, jog, etc.) can be selected through P0-02 and DI terminals:

FC200 running command channel	Illustrate
Operation panel	The keys on the operation panel to control the start and stop of the inverter.
Control terminal	Use the control terminals to control the start and stop of the inverter.
MUDBUS communication	Through 485 communication.

5.1.2 Frequency setting channel

The final frequency set by FC200 is obtained from the main setting channel (P0-03) and the auxiliary setting channel (P0-04) after calculation (P0-07) . When the auxiliary setting channel is the same as the main setting channel (except analog), the frequency is set by the main setting channel.

Main setting frequency channel (parameter P0-03)	Auxiliary setting frequency channel (parameter P0-04)	Remark
0: Digital setting, P0-08 sets the initial value, no memory when power off	0: Digital setting, P0-08 sets the initial value, no memory when power off	Operation panel ▲, ▼ adjustment
1: Digital setting, P0-08 setting initial value, power-off memory	1: Digital setting, P0-08 setting initial value, power-off memory	Terminal UP/DN adjustment
2: AI1	2: AI1	
3: AI2	3: AI2	
4: AI3 keyboard potentiometer	4: AI3 keyboard potentiometer	
5: PLUSE pulse setting (DI5)	5: PLUSE pulse setting (DI5)	DI5 terminal P4-04 is set to 30
6: Multi-segment instructions	6: Multi-segment instructions	
7: Simple PLC	7: Simple PLC	
8: PID	8: PID	
9: Communication setting	9: Communication setting	

5.1.3 Working status

FC200 working status	Illustrate
Downtime	After the inverter is powered on and initialized, if there is no running command input, or after the stop command is executed during running, the U/V/W terminals of the inverter will have no output, and the running status indicator on the operation panel will flash.

FC200 working status	Illustrate
Operating status	After the inverter receives the running command, the U/V/W terminals of the inverter start to output, and the running status indicator on the operation panel is always on.
Motor parameter self-tuning status	P1-37 is set to 1 or 2 or 3, the inverter receives the running command and enters the motor parameter self-tuning state. After the self-tuning is completed, it will automatically enter the shutdown state.
System running status	Refers to the state where the U/V/W terminals of the inverter have output or zero-frequency blocked output or sleep and wait for restart. In this state, the running status indicator on the operation panel is always on, and the LED flashes to display the parameters in the stop state, and the parameters that cannot be modified during the operation of the inverter cannot be modified.

5.1.4 Operating mode

FC200 operating mode	Illustrate
Process PID adjustment operation	Process PID adjustment operation function is valid (P0-03=8), the inverter will select the process PID adjustment operation mode, that is, perform PID adjustment according to the setting and feedback amount (PA group needs to be set).
Multi-stage speed operation	The logical combination of DI terminals (12-1 No. 5 function), select the multi-stage frequency 1-16 (PC .00- PC .15) for multi-stage speed operation.
Simple PLC operation	Simple PLC function selection is valid (P0-03 = 7), the inverter will run in the simple PLC mode, and the inverter will run according to the preset operating parameters (see the parameters of the PC group) .

5.1.5 Operation Panel Description

The operation panel can be used to modify the function parameters of the inverter, monitor the working status of the inverter and control the operation (start, stop) of the inverter, etc. Its appearance and function area are shown in the following figure:

FC200 is equipped with a double-digit LED operation panel as standard, and the keys and functions of the operation panel are shown in Figure 5-1 Schematic diagram of the operation panel Shows as Table 5-1



Figure5-1 Schematic diagram of the operation panel

Table 5-2 Operation panel key description

Button	Function	
PRG	Programming key	First-level menu entry or exit
ENTER	Enter	Enter the menu screen step by step, confirm the setting parameters
RUN	Run key	When the operation panel is controlled, start the inverter
STOP RST	Stop/RST	a. When the operation panel is controlled, stop the inverter b. When a fault is detected, it is a fault reset button
MFK	Multi-function selection key	Multi-function selection key: switch function according to P7-01
▲	Increment key	Increment of function parameter or parameter setting value
▼	Down key	Function parameter and parameter setting value decrement
▶	Shift key	a. Select the modification bit of the setting data b. Cyclic switching stop/run display status parameters

4 status indicator lights and 3 unit indicator lights on the FC200 operation panel , and the meanings of the indicator lights and display states are shown in Table 5-3 .

Table 5-3 Description of the indicator lights on the operation panel

Logo	Indicator name	(Always on) Description	(Flashing) Description	(Not lit) Description
RUN	Operating status	When the light is on, it means the inverter is running		When the light is on, it means the inverter is in the stop state
L/R	Keypad, terminal and remote operation (communication control) status	The current terminal start-stop control mode	The current communication start-stop control mode	The current keyboard start-stop control mode
F/R	Forward and reverse running status	The current inverter is forward and reverse		The current inverter is reverse reverse
TU/TC	Tuning / Torque Control / Fault Status	Lights on to indicate torque control mode	The light flashes slowly to indicate that it is in tuning state The light flashes quickly to indicate that it is in a fault state	The current Frequency Inverter is not faulty
Hz	Frequency unit	The unit of the current parameter is Hz	The current parameter is the output frequency	
A	Current unit	The unit of the current parameter is A		
V	Voltage unit	The unit of the current parameter is V		

FC200 has a 5-digit LED digital tube, and the display meanings are shown in Table 5-4 .

Table 5-4 Nixietube display instructions







































LED display	Meaning	LED display	Meaning	LED display	Meaning	LED display	Meaning
	0		A		J		U
	1		b		L		u
	2		C		no		The y
	3		c		o		-
	4		d		P		Point
	5		E.		q		Show all
	6		f		r		No display
	7		h		S		Flashing Can be modified
	8		h		T		
	9		i		t		

Table 5-4 key switching four-level menu description

Button	First level menu	Second level menu	Third level menu	Fourth level menu
RRG	When there is a fault, return to the fault display. When there is no fault, return to the display of running or stopping state	Return to first level menu	Return to second level menu	Do not save the current value and return to the third-level menu
←	Enter the second level menu	Enter the third level menu	Enter the fourth level menu	Save the current value and return to the third level menu
▲	Select a functional group. Loop according to P0 - PP - A0 - U0	Modify the function number. Press 1 time to add 1 to the value of the current modified bit	Modify the internal number of the function group. Press 1 time to add 1 to the value of the current modified bit	Modify the function code value. Press 1 time to add 1 to the value of the current modified bit
▼	Select a functional group. Loop according to P0 - PP - A0 - U0	Modify the function number. Press 1 time to subtract 1 from the value of the current modification bit	Modify the internal number of the function group. Press 1 time to subtract 1 from the value of the current modified bit	Modify the function code value. Press 1 time to subtract 1 from the value of the current modified bit
▶▶	Invalid	Invalid	Switch between ones and tens	Ones, Ten Thousands, Thousands, Hundreds, Tens cycle switching

Chapter 6 Brief Introduction of Function Parameters

6.1 Brief table of basic function parameters

" ☆ ": Indicates that the setting value of this parameter can be changed when the inverter is in stop or running state;
 " ★ ": Indicates that the setting value of this parameter cannot be changed when the inverter is in running state;
 " ● ": Indicates that the value of this parameter is the actual detection record value and cannot be changed;

Function code	Name	Setting range	Factory default	Attributes	DEC address
P0 group Basic parameters					
P0-00	G/P model	1: G type 2: P type	1	★	61440
P0-01	Motor control method	0: Speed sensorless vector control 2: V/F control	2	★	61441
P0-02	Command source selection	0: Panel command channel (L/R LED off) 1: Terminal command channel (L/R LED on) 2: Communication command channel (L/R LED flashing)	0	☆	61442
P0-03	Main frequency source X selection	0: Digital setting (preset frequency P0-08,UP/DOWN can be modified,no memory when power off) 1: Digital setting (preset frequency P0-08,UP/DOWN can be modified,memory when power off) 2: AI1 3: AI2 4: AI3 keyboard potentiometer 5: PLUSE pulse setting(DI5) 6: Multi-segment command 7: Simple PLC 8: PID 9: Communication given	4	★	61443
P0-04	Auxiliary frequency source Y selection	Same as P0-03 (main frequency source X selection)	0	★	61444

Function code	Name	Setting range	Factory default	Attributes	DEC address
P0-05	Frequency source Y during superposition range selection	0: relative to the maximum frequency 1 : relative to the frequency source X	0	☆	61445
P0-06	Frequency source Y range when superimposed	0% ~ 150%	100%	☆	61446
P0-07	Frequency source superposition mode selection	Units place: Frequency source selection 0: Main frequency source X 1: Main and auxiliary operation (the operation method is determined by the tens place) 2: Main frequency source X and auxiliary frequency source Y switching 3: Main frequency source X and main and auxiliary operation results Switching 4: Auxiliary frequency source Y and main-auxiliary operation result switching Tens digit: frequency source main-auxiliary operation relationship 0: main + auxiliary 1: main-auxiliary 2: maximum value of both 3: minimum value of both 4: main x auxiliary 5: main ÷ auxiliary Note : When using the main ÷ auxiliary, pay attention to the main adjustment to the minimum value first, and the auxiliary adjustment to the maximum value	00	☆	61447

P0-08	Preset frequency	0.00Hz~maximum frequency (P0-10)	50.00Hz	☆	61448
P0-09	Running direction	0: same direction 1: opposite direction	0	☆	61449
P0-10	Maximum frequency	50.00Hz~500.00Hz	50.00Hz	☆	61450
P0-11	Upper limit frequency source	0: P0-12 setting 1: AI1 2: AI2 3: AI3 external keyboard potentiometer 4: HDI pulse setting 5: Communication setting	0	★	61451
P0-12	Upper limit frequency	Lower limit frequency P0-14 ~ maximum frequency P0-10	50.00Hz	☆	61452
P0-13	Upper limit frequency offset	0.00Hz~maximum frequency P0-10	0.00Hz	☆	61453
P0-14	Lower limit frequency	0.00Hz~upper limit frequency P0-12	0.00Hz	☆	61454
P0-15	Carrier frequency	0.5kHz~16.0kHz	Model confirmed	☆	61455
P0-16	Carrier frequency adjusted with temperature	0: no 1: yes	1	☆	61456
P0-17	Acceleration time 1	0s~65000s (P0-19 =0) 0.0s~ 6500.0s (P0-19 = 1)	Model confirmed	☆	61457
P0-18	Deceleration time 1	0.0 0s~650.00s (P0-19 =2)			61458
P0-19	Acceleration and deceleration time unit	0: 1 second 1: 0.1 second 2: 0.01 second	1	★	61459

Function code	Name	Setting range	Factory default	Attributes	DEC address
P0-21	Auxiliary frequency source during superposition Bias frequency	0.00Hz~maximum frequency P0-10	0.00Hz	☆	61461
P0-22	Reserve	-	-	-	-
P0-23	Digital setting frequency stop memory	0: no memory 1: Memory	1	☆	61463
P0-24	Reserve	-	1	☆	61464
P0-25	Acceleration and deceleration time base frequency	0: maximum frequency (P0-10) 1: set frequency	0	★	61465
P0-26	Frequency command UP/DOWN reference during operation	0: Running frequency 1: Setting frequency	0	★	61466
P0-27	Command source bundled frequency source	Units: Operation panel command binding frequency source selection 0: No binding 1: Digital setting frequency 2: AI1 3: AI2 4: AI3 external keyboard potentiometer 5: PLUSE pulse setting (DI5) 6: Multi-stage speed 7: Simple PLC 8: PID	0000	☆	61467

		<p>9 : Tens digit of communication reference : terminal command binding frequency source selection</p> <p>Hundreds place: communication command binding frequency source selection</p> <p>Thousands place: automatic operation binding frequency source selection</p>			
P0-29	Application macro	<p>Setting range : 0 ~ 65535 1000</p> <p>0: function code restore factory default macro 1: Variable frequency single pump constant pressure water supply macro 2: One to three constant pressure water supply macros (1 to 2 works) 3: One to five constant pressure water supply macro (1 to 4 works) 7: fire inspection water supply macro 11: CNC machine tool 100 Hz macro 1 12: CNC machine tool 100 Hz macro 2 21: Spindle engraving 400 Hz macro 1 22: Spindle engraving 400 Hz macro 2</p> <p>Note 1: Before selecting the macro number , first execute P0-29 to restore the factory value, and then select the macro number. Note 2: See b0 parameter group for details of one-to-many water supply</p>	0	☆	61469

Function code	Name	Setting range	Factory default	Attributes	DEC address
Group P1 Motor Parameters					
P1-00	Motor Type Selection	0: Ordinary asynchronous motor 1 : Variable frequency asynchronous motor 2: Reserve	0	★	61696
P1-01	Motor rated power	0.1~1000KW	Model confirmed	★	61697
P1-02	Motor rated voltage	1~2000V	Model confirmed	★	61698
P1-03	Motor rated current	0.01~655.35A (inverter power ≤ 55 kW) 0.1~6553.5A (inverter power > 55 kW)	Model confirmed	★	61699
P1-04	Motor rated frequency	0.01Hz~maximum frequency	Model confirmed	★	61700
P1-05	Motor rated speed	1~65535rpm	Model confirmed	★	61701
P1-06	Asynchronous motor stator resistance	0.001Ω ~ 65.535Ω (inverter power ≤ 55 kW) 0.0001Ω ~ 6.5535Ω (inverter power > 55 kW)	Model confirmed	★	61702
P1-07	Asynchronous motor rotor resistance	0.001Ω ~ 65.535Ω (inverter power ≤ 55 kW) 0.0001Ω ~ 6.5535Ω (inverter power > 55 kW)	Model confirmed	★	61703
P1-08	Asynchronous motor leakage inductance	0.01mH ~ 655.35mH (inverter power ≤ 55 kW) 0.001mH ~ 65.535mH (inverter power > 55 kW)	Model confirmed	★	61704

P1-09	Mutual inductance reactance of asynchronous motor	0.1mH ~ 6553.5mH (inverter power \leq 55 kW) 0.01mH ~ 655.35mH (inverter power $>$ 55 kW)	Model confirmed	★	61705
P1-10	Asynchronous motor no-load current	0.01~P1-03	Tuning parameters	★	61706
P1-37	Tuning selection	0: no operation 1 : static tuning of asynchronous machine 2 : complete tuning of asynchronous machine 3: Static tuning 2	0	★	61733
P2 Group vector parameters					
P2-00	Speed loop proportional gain 1	1~100	30	☆	61952
P2-01	Speed loop integration time 1	0.01~10.00s	0.50s	☆	61953
P2-02	Switching frequency 1	0.00~P2-05	5.00Hz	☆	61954
P2-03	Speed loop proportional gain 2	1~100	20	☆	61955
P2-04	Speed loop integration time 2	0.01s~10.00s	1.00s	☆	61956
P2-05	Switching frequency 2	P2-02~maximum frequency	10.00Hz	☆	61957
P2-06	Vector control slip gain	50~200%	150%	☆	61958
P2-07	Speed loop filter time constant	0.000~0.100s	0.000s	☆	61959

Function code	Name	Setting range	Factory default	Attributes	DEC address
P2-08	Vector control overexcitation gain	0~200	64	☆	61960
P2-09	Torque upper limit source in speed control mode	0: Function code P2-10 setting 1: AI1 2: AI2 3: Keyboard potentiometer 4: PULSE pulse setting 5: Communication setting 6: MIN (AI1, AI2) 7: MAX (AI1, AI2) The full range of options 1-7 corresponds to P2-10	0	☆	61961
P2-10	In speed control mode Torque upper limit digital setting	0.0% ~ 200.0%	150.0%	☆	61962
P2-13	Excitation regulation proportional gain	0~60000	2000	☆	61965
P2-14	Excitation regulation integral gain	0~60000	1300	☆	61966
P2-15	Torque regulation proportional gain	0~60000	2000	☆	61967
P2-16	Torque adjustment integral gain	0~60000	1300	☆	61968
P2-17	Speed Loop Integral Properties	Units: Integral separation 0: invalid 1: Valid	0	☆	61969
P3 group V/F control parameters					

P3-00	VF curve setting	0: Straight line V/F 1: Multi-point V/F 2: Square V/F 3: 1.2 power V/F 4: 1.4 power V/F 6: 1.6 power V/F 8: 1.8 power V/F 9: Reserved 10: V/F completely separated 11: V/F half separation	0	★	62208
P3-01	Torque boost	0.0%: (automatic torque boost) 0.1 ~ 30.0%	Model confirmed	☆	62209
P3-02	Torque boost cut-off frequency	0.00Hz~maximum frequency	50.00Hz	★	62210
P3-03	Multi-point V/F frequency point 1	0.00Hz~P3-05	0.00Hz	★	62211
P3-04	Multi-point V/F voltage point 1	0.0%~100.0%	0.0%	★	62212
P3-05	Multi-point V/F frequency point 2	P3-03~P3-07	0.00Hz	★	62213
P3-06	Multi-point V/F voltage point 2	0.0%~100.0%	0.0%	★	62214
P3-07	Multi-point V/F frequency point 3	P3-05~motor rated frequency (P1-04)	0.00Hz	★	62215
P3-08	Multi-point VF voltage point 3	0.0%~100.0%	0.0%	★	62216
P3-09	V/F slip compensation gain	0.0%~200.0%	0.0%	☆	62217
P3-10	V/F overexcitation gain	0~200	64	☆	62218

Function code	Name	Setting range	Factory default	Attributes	DEC address
P3-11	V/F oscillation suppression gain	0~100	Model confirmed	☆	62219
P3-13	VF Separate voltage source	0: Digital setting (P3-14) 1: AI1 2: AI2 3: AI3 (keyboard potentiometer) 4: PULSE (DI5) 5: Multi-segment instructions 6: Simple PLC 7: PID 8: Communication given			
P3-14	VF separation voltage digital setting	0V ~ motor rated voltage			
P4 Group input terminal					
P4-00	DI1 terminal function selection	0: No function 1: Forward running (FWD) 2: Reverse running (REV) 3: Three-wire running control 4: Forward jogging (FJOG) 5: Reverse jogging (RJOG) 6: Terminal UP 7: Terminal DOWN 8: Free stop 9: Fault reset (RST) 10: Running pause 11: External fault normally open input 12: Multi-segment command terminal 1 13: Multi-segment command terminal 2 14: Multi-segment command terminal 3 15: Multi-segment command terminal 4	01	★	62464
P4-01	DI2 terminal function selection		02	★	62465
P4-02	DI3 terminal function selection		04	★	62466
P4-03	DI4 terminal function selection		09	★	62467
P4-04	DI5 terminal function selection		12	★	62468
P4-05	Reserve		00	★	62469

P4-06	Reserve	<p>16: Acceleration and deceleration time selection terminal 1</p> <p>17: Acceleration and deceleration time selection terminal 2</p> <p>18: Frequency source switching</p> <p>19: UP/DOWN setting reset (terminal/keyboard)</p> <p>20: Running command switching terminal 1</p> <p>21: Acceleration and deceleration prohibited</p> <p>22: PID pause</p> <p>23: PLC status reset</p> <p>24: Wobble frequency pause</p> <p>25: Counter input</p> <p>26: Counter reset</p> <p>27: Length count input</p> <p>28: Length reset</p> <p>29: Torque control prohibited</p> <p>30: PLUSE pulse frequency input (DI5)</p> <p>31: Reserved</p> <p>32: Immediate DC braking</p> <p>33: External fault normally closed input</p> <p>34: Frequency modification enabled</p> <p>35: PID action direction reversed</p> <p>36: External stop terminal 1</p> <p>37: Switching of running command Terminal 2</p> <p>38: PID integral pause</p> <p>39: Switching between frequency source X and preset frequency</p> <p>40: Switching between frequency source Y and preset frequency</p> <p>43: Switching between PID parameters</p> <p>44: User-defined fault 1</p> <p>45: User-defined fault 2</p>	00	★	62470
-------	---------	---	----	---	-------

Function code	Name	Setting range	Factory default	Attributes	DEC address
		46: speed control/torque control switching 47: emergency stop 48: external stop terminal 2 49: deceleration DC braking 50: clear the current running time 51: Two-wire and three-wire switching 52: No reverse 53: Single terminal UP/DOWN enable , frequency source switching (same as function 18) 54: Terminal active UP Inactive is DOWN 55: Fire mode trigger terminal			
P4-10	DI terminal filter time	0.000s~1.000s	0.010s	☆	62474
P4-11	Terminal command mode	0: Two-line type 1 1 : Two-line type 2 2: Three-wire type 1 3: Three-wire type 2	0	★	62475
P4-12	Terminal UP/DOWN change rate	0.001Hz/s~65.535Hz/s	1.00Hz/s	☆	62476
P4-13	AI curve 1 minimum input	0.00V~P4-15	0.00V	☆	62477
P4-14	AI curve 1 minimum input corresponding setting	-100.0%~+100.0%	0.0%	☆	62478
P4-15	AI curve 1 maximum input	P4-13~+10.00V	10.00V	☆	62479

P4-16	AI curve 1 maximum input corresponding setting	-100.0%~+100.0%	100.0%	☆	62480
P4-17	AI1 filter time	0.00s~10.00s	0.10s	☆	62481
P4-18	AI curve 2 minimum input	0.00V~P4-20	0.00V	☆	62482
P4-19	AI curve 2 minimum input corresponding setting	-100.0%~+100.0%	0.0%	☆	62483
P4-20	AI curve 2 maximum input	P4-18~+10.00V	10.00V	☆	62484
P4-21	AI curve 2 maximum input corresponding setting	-100.0%~+100.0%	100.0%	☆	62485
P4-22	AI2 filter time	0.00s~10.00s	0.10s	☆	62486
P4-23	AI curve 3 minimum input	0.00V~P4-25	0.00V	☆	62482
P4-24	AI curve 3 minimum input corresponding setting	-100.0%~+100.0%	0.0%	☆	62483
P4-25	AI Curve 3 Maximum Input	P4-23~+10.00V	10.00V	☆	62484
P4-26	AI curve 3 maximum input corresponding setting	-100.0%~+100.0%	100.0%	☆	62485

Function code	Name	Setting range	Factory default	Attributes	DEC address
P4-27	AI3 filter time	0.00s~10.00s	0.10s	☆	62486
P4-28	DI5 pulse minimum input	0.00kHz~P4-30	0.00kHz	☆	62492
P4-29	DI5 pulse minimum input corresponding setting	-100.0%~100.0%	0.0%	☆	62493
P4-30	DI5 pulse maximum input	P4-28~50.00kHz	50.00kHz	☆	62494
P4-31	DI5 pulse maximum input setting	-100.0%~100.0%	100.0%	☆	62495
P4-32	DI5 pulse filter time	0.00s~10.00s	0.10s	☆	62496
P4-33	AI curve selection	Bit: AI1 curve selection 1: Curve 1 (2 points, P4-13~P4-16) 2: Curve 2 (2 points, P4-18~P4-21) 3: Curve 3 (2 points, P4-23~P4-26) Tens digit: AI2 curve selection, same as above Hundreds digit: AI3 curve selection, same as above	321	☆	62497
P4-34	AI below minimum input setting selection	Units: AI1 is lower than the minimum input setting selection 0: corresponding to the minimum input setting 1: 0.0% Tens digit: AI2 is lower than the minimum input setting selection, the same as above	000	☆	62498

		hundreds digit: AI3 is lower than the minimum input setting selection, the same as above		▪	
P4-35	DI terminal effective mode selection 1	0: High level is effective 1 : Low level is effective Units: DI1 Tens: DI2 Hundreds: DI3 Thousands place: DI4 Ten thousand digits: DI5	000	★	62499
P4-37	AI input voltage/ current selection	Units : AI1 Tens : AI2 0: voltage input 1: current input	10	★	62501
P4-38	DI1 conduction delay time	0.0s~6553.5s	0.0S	★	62502
P4-39	DI2 conduction delay time	0.0s~6553.5s	0.0S	★	62503
P4-40	DI3 conduction delay time	0.0s~6553.5s	0.0S	★	62504
P4-41	DI4 conduction delay time	0.0s~6553.5s	0.0S	★	62505
P4-42	DI5 conduction delay time	0.0s~6553.5s	0.0S	★	62506
P4-43	Reserve	-	-	-	-
P4-44	Reserve	-	-	-	-
P4-48	DI1 off delay time	0.0s~6553.5s	0.0S	★	62512

Function code	Name	Setting range	Factory default	Attributes	DEC address
P4-49	DI2 off delay time	0.0s~6553.5s	0.0S	★	62513
P4-50	DI3 off delay time	0.0s~6553.5s	0.0S	★	62514
P4-51	DI4 off delay time	0.0s~6553.5s	0.0S	★	62515
P4-52	DI5 off delay time	0.0s~6553.5s	0.0S	★	62516
P4-53	Reserve	-	-	☆	-
P4-54	Reserve	-	-	☆	-
P5 Group output terminal					
P5-00	FM terminal output mode selection	0: High-speed pulse output (FMP) 1: Terminal switch output (FMR)	0	☆	62720
P5-01	FMR terminal switching value Output function selection	0: No output 1: Inverter running 2: Fault output (failure shutdown) 3: Frequency level detection FDT1 output	0	☆	62721
P5-02	Relay RY1 function selection (RA-RB-RC)	4: Frequency reached 5: Running at zero speed (no output when stopped) 6: Motor overload pre-alarm 7: Frequency conversion Overload pre-alarm	2	☆	62722
P5-03	Relay RY2 function selection (TA-TB-TC)	8: Set count value reached 9: Specified count value reached 11: PLC cycle completed 12: Accumulated running time reached 13: Frequency limited 14: Torque limited 15: Ready to run 16: AI1>AI2	0	☆	62723

P5-04	DO1 output function selection (J4 jumper to DO1 position - 45kW and above models)	17: The upper limit frequency is reached 18: The lower limit frequency is reached (related to operation) 19: Undervoltage state output 20: Communication setting 23: Zero speed running 2 (output even when stopped) 24: Accumulated power-on time is reached 25: Frequency level detection FDT2 Output 26: frequency 1 reaches output 27: frequency 2 reaches output 28: current 1 reaches output 29: current 2 reaches output 30: timing reaches output 31: AI1 input overrun 32: load shedding 33: reverse running 34: zero Current state 35: module temperature reaches 36: output current exceeds limit 37: lower limit frequency reaches (stops and outputs also) 38: alarm output (continues to run) 40: current running time reaches 41: fault output (for free stop fault and under Pressure does not output) 42: frequency 1 < = running frequency < = frequency 2 43: frequency 1 > = operating frequency > = frequency 2 44: Frequency 1 < = set frequency < = frequency 2	1	☆	62724
-------	---	---	---	---	-------

Function code	Name	Setting range	Factory default	Attributes	DEC address
		45: frequency 1 > = set frequency > = frequency 2 (Note: Frequency 1, 2 refers to P8-30, P8-32) 46: linkage DI1 terminal output 47: linkage DI2 terminal output 48: linkage DI3 terminal output 49: linkage DI4 terminal output 50: Auxiliary motor water pump 1 51: Auxiliary motor water pump 2 52: auxiliary motor water pump 3 53: auxiliary motor water pump 4 54: Sleeping			
P5-06	FMP high speed pulse Output function selection	0: Running frequency 1: Set frequency 2: Output current 3: Output torque 4: Output power	0	☆	62726
P5-07	AO1 output function selection	5: Output voltage 6: HDI pulse input (100.% corresponds to 100.0kHz)	0	☆	62727
P5-08	AO2 output function selection (J4 jumper to AOV2 position - 45kW and above models)	7: AI1 8: AI2 9: AI3 11: Counter value 12: Communication setting 13: Motor speed 14: Output current (100.0% corresponds to 1000.0A) 15: Output voltage (100.0% corresponds to 1000.0V) 16: reserved 17: Inverter output torque	0	☆	62728

P5-09	FMP output maximum frequency	0.01kHz~50.00kHz	50.00kHz	☆	62729
P5-10	AO1 zero bias coefficient	-100.0%~+100.0%	0.0%	☆	62730
P5-11	AO1 gain	-10.00~+10.00	1.00	☆	62731
P5-12	AO2 zero bias coefficient	-100.0%~+100.0%	0.0%	☆	62732
P5-13	AO2 Gain	-10.00~+10.00	1.00	☆	62733
P5-17	FMR delay delay time	0.0s~6553.5s	0.0s	☆	62737
P5-18	RY1 delay closing time	0.0s~6553.5s	0.0s	☆	62738
P5-19	RY2 delay closing time	0.0s~6553.5s	0.0s	☆	62739
P5-20	AO2 delay closing time	0.0s~6553.5s	0.0s	☆	62740
P5-21	Reserve	-	-	☆	62741
P5-22	Output terminal active state selection	0: positive logic 1: negative logic Units: FM terminal _ Tens: RY1 Hundreds place: RY 2 Thousands: AO2 _ Ten thousand digits: reserved	00000	☆	62742
P5-23	AO current output selectio	Units: AO1 Tens place: AO2 0: 0~20mA 1: 4~20mA	00	☆	62743
P5-24	FMR delay off time	0.0s~6553.5s	0.0s	☆	62744
P5-25	RY1 delay off time	0.0s~6553.5s	0.0s	☆	62745

Function code	Name	Setting range	Factory default	Attributes	DEC address
P5-26	RY2 delay off time	0.0s~6553.5s	0.0s	☆	62746
P5-27	AO2 delay off time	0.0s~6553.5s	0.0s	☆	62747
P6 Group start and stop control					
P6-00	Start method	0: Direct start 1: Speed tracking restart 2: Pre-excitation start (AC asynchronous machine)	0	☆	62976
P6-01	Speed tracking method	0: Start from stop frequency 1: Start from zero speed 2: Start from maximum frequency	0	★	62977
P6-02	Speed tracking speed	1~100	20	☆	62978
P6-03	Start frequency	0~P0-08	0.00Hz	☆	62979
P6-04	Starting frequency hold time	0.0s~100.0s	0.0s	★	62980
P6-05	Starting DC braking current / pre-excitation current	0%~100%	0%	★	62981
P6-06	Start DC braking time / pre-excitation time	0.0s~100.0s	0.0s	★	62982
P6-07	Acceleration and deceleration mode	0: Linear acceleration and deceleration 1: S-curve acceleration and deceleration A 2: S-curve acceleration and deceleration B	0	★	62983

P6-08	S-curve start period time ratio	0.0%~(100.0%-P6-09)	30.0%	★	62984
P6-09	S-curve end time ratio	0.0%~(100.0%-P6-08)	30.0%	☆	62985
P6-10	Shutdown mode	0: decelerate to stop 1: free parking	0	☆	62986
P6-11	Start frequency of DC braking at stop	0.00Hz~maximum frequency	0.00Hz	☆	62987
P6-12	Stop DC braking waiting time	0.0s~100.0s	0.0s	☆	62988
P6-13	Stop DC brake current	0%~100%	0%	☆	62989
P6-14	Stop DC braking time	0.0s~100.0s	0.0s	☆	62990
P6-15	Brake usage	0%~100%	100%	☆	62991
P7 Group keyboard and display					
P7-00	Display function extension 1	Units : power supply voltage monitoring mode 0: DC bus voltage 1: Input AC voltage (with U letter in front)	00000	☆	63232
P7-01	MF.K key function selection	0: MF.K is invalid 1: Switch between operation panel command channel and remote command channel (terminal command channel or communication command channel) 2: Forward and reverse switching 3: Forward jogging 4: Reverse jogging	0	☆	63233

Function code	Name	Setting range	Factory default	Attributes	DEC address
P7-02	STOP/RST key function	0: Only in the keyboard operation mode, the stop function of the STOP/RES key is valid 1: In any operation mode, the stop function of the STOP/RES key is valid	1	☆	63234
P7-03	LED running display parameter 1	0000~FFFF Bit00: Operating frequency 1 (Hz) Bit01: Setting frequency (Hz) Bit02: Bus voltage (V) Bit03: Output voltage (V) Bit04: Output current (A) Bit05: Output power (kW) Bit06: Output Torque (%) Bit07: X input state Bit08: Y output state Bit09: AI1 voltage (V) Bit10: AI2 voltage (V) Bit11: AI3 panel potentiometer voltage (V) Bit12: Count value Bit13: Reserve Bit14: load speed display Bit15: PID setting (water supply macro display pressure value)	001F	☆	63235
P7-04	LED running display parameter 2	0000~FFFF Bit00 : PID feedback (water supply macro display pressure value) Bit01: PLC stage Bit02: PLUSE input pulse frequency (kHz) Bit03: Running frequency 2 (Hz)	0000	☆	63236

		Bit04: Remaining running time Bit05: AI1 voltage before correction (V) Bit06: Voltage before AI2 correction (V) Bit07: Voltage before AI3 panel potentiometer correction (V) Bit08: Line speed Bit09: Current power-on time (Hour) Bit10: Current running time (Min) Bit11: PLUSE input pulse frequency (Hz) Bit12: Communication setting value Bit13:Reserve Bit14: Main frequency X display (Hz) Bit15: Auxiliary frequency Y display (Hz)			
P7-05	LED shutdown display parameters	0000~FFFF Bit00: Set frequency (Hz) Bit01: Bus voltage (V) Bit02: X input state Bit03: Y output state Bit04: AI1 voltage (V) Bit05: AI2 voltage (V) Bit06: AI3 panel potentiometer voltage (V) Bit07: Count value Bit08: Length value Bit09: PLC stage Bit10: Load speed Bit11: PID setting (pressure)	0033	☆	63237

Function code	Name	Setting range	Factory default	Attributes	DEC address
		Bit12: PLUSE input pulse frequency (kHz) Bit13: PID feedback (pressure)			
P7-06	Load speed display factor	0.0001~6.5000	1.0000	☆	63238
P7-07	Inverter module heat sink temperature	0.0°C ~ 100.0°C	-	●	63239
P7-09	Cumulative running time	0h~65535h	-	☆	63241
P7-12	Load speed display decimal places	0:0 decimal places 1:1 decimal places 2:2 decimal places 3:3 decimal places	1	☆	63244
P7-13	Cumulative power-on time	0~65535h	-	●	63245
P7-14	Cumulative power consumption	0~65535 degrees	-	●	63246
P7-17	Nixie tube 2 stop monitoring selection	00~99 (corresponding to group U0 parameter number)	02	☆	63249
P7-18	Nixie tube 2 running monitoring selection	00~99 (corresponding to group U0 parameter number)	04	☆	63250
P8 Group auxiliary function					
P8-00	Jog running frequency	0.00Hz~maximum frequency	6.00Hz	☆	63488
P8-01	Jog acceleration time	0.0s~6500.0s	20.0s	☆	63489

P8-02	Jog deceleration time	0.0s~6500.0s	20.0s	☆	63490
P8-03	Acceleration time 2	0.0s~6500.0s	Model confirmed	☆	63491
P8-04	Deceleration time 2	0.0s~6500.0s	Model confirmed	☆	63492
P8-05	Acceleration time 3	0.0s~6500.0s	Model confirmed	☆	63493
P8-06	Deceleration time 3	0.0s~6500.0s	Model confirmed	☆	63494
P8-07	Acceleration time 4	0.0s~6500.0s	Model confirmed	☆	63495
P8-08	Deceleration time 4	0.0s~6500.0s	Model confirmed	☆	63496
P8-09	Jump frequency 1	0.00Hz~maximum frequency	0.00Hz	☆	63497
P8-10	Jump frequency 2	0.00Hz~maximum frequency	0.00Hz	☆	63498
P8-14	The set frequency is lower than the lower limit frequency operating mode	0: Run at the lower limit frequency 1: Stop 2: Run at zero speed	0	☆	63502
P8-15	Droop control	0.00Hz~10.00Hz	0.00Hz	☆	63503
P8-16	Set the cumulative power-on arrival time	0h~65000h	0h	☆	63504
P8-17	Set the cumulative running arrival time	0h~65000h	0h	☆	63505
P8-18	Boot Protection Selection	0: no protection 1: protection	0	☆	63506

Function code	Name	Setting range	Factory default	Attributes	DEC address
P8-19	Frequency detection value (FDT1)	0.00Hz~maximum frequency	50.00Hz	☆	63507
P8-20	Frequency detection hysteresis value	0.0%~100.0% (FDT1 level)	5.0%	☆	63508
P8-21	Frequency arrival detection width	0.0%~100.0% (maximum frequency)	0.0%	☆	63509
P8-25	Acceleration time 1 with Acceleration time 2 switching frequency point	0.00Hz~maximum frequency	0.00Hz	☆	63513
P8-26	Deceleration time 1 and Deceleration time 2 switching frequency point	0.00Hz~maximum frequency	0.00Hz	☆	63514
P8-27	Terminal jog priority	0: invalid 1: valid	0	☆	63515
P8-28	Frequency detection value (FDT2)	0.00Hz~maximum frequency	50.00Hz	☆	63516
P8-29	Frequency detection hysteresis value	0.0%~100.0% (FDT2 level)	5.0%	☆	63517

P8-30	Arbitrary arrival frequency detection value 1	0.00Hz~maximum frequency	50.00Hz	☆	63518
P8-31	Arbitrary arrival frequency detection width 1	0.0%~100.0% (maximum frequency)	0.0%	☆	63519
P8-32	Arbitrary arrival frequency detection value 2	0.00Hz~maximum frequency	50.00Hz	☆	63520
P8-33	Arbitrary arrival frequency detection width 2	0.0%~100.0% (maximum frequency)	0.0%	☆	63521
P8-34	Zero current detection level	0.0%~300.0%	5.0%	☆	63522
P8-35	Zero current detection delay time	0.01s~600.00s	0.10s	☆	63523
P8-36	Output current exceeds limit	0.0% (no detection)	200.0%	☆	63524
P8-37	Output current overrun detection delay time	0.00s~600.00s	0.00s	☆	63525
P8-38	Arbitrary arrival current 1	0.0%~300.0% (motor rated current)	100.0%	☆	63526
P8-39	Arbitrary arrival current 1 width	0.0%~300.0% (motor rated current)	0.0%	☆	63527

Function code	Name	Setting range	Factory default	Attributes	DEC address
P8-40	Arbitrary arrival current 2	0.0%~300.0% (motor rated current)	100.0%	☆	63528
P8-41	Arbitrary arrival current 2 width	0.0%~300.0% (motor rated current)	0.0%	☆	63529
P8-42	Timing function selection	0: invalid 1: valid	0	☆	63530
P8-43	Timing run time selection	0: P8-44 setting 1: AI1 2: AI2 3: AI3 Note: Analog input range corresponds to P8-44	0	☆	63531
P8-44	Timing run time	0.0Min~6500.0Min	0.0Min	☆	63532
P8-45	AI1 input voltage protection value lower limit	0.00V~P8-46	3.10V	☆	63533
P8-46	AI1 input voltage protection upper limit	P8-45~10.00V	6.80V	☆	63534
P8-47	Module temperature reaches	0°C ~100°C	75 °C	☆	63535
P8-48	Fan control	0: The fan turns when running 1: The fan keeps turning	0	☆	63536
P8-49	Wakeup frequency	Sleep frequency (P8-51) ~ maximum frequency (P0-10)	0.00Hz	☆	63537
P8-50	Wake up delay time	0.0s~6500.0s	0.0s	☆	63538

P8-51	Sleep frequency	0.00Hz~wake-up frequency (P8-49)	0.00Hz	☆	63539
P8-52	Sleep delay time	0.0s~6500.0s	0.0s	☆	63540
P8-53	Arrival time setting for this run	0.0Min~6500.0Min	0.0Min	☆	63541
P8-55	Fire mode selection	0: No function 1: Fire mode 1 2: Fire mode 2 3: Fire mode 3 4: Fire mode 4	0	★	63543
P8-56	Force run frequency	0.00Hz ~ Maximum frequency (P0-10)	50.00Hz	★	63544
P8-58	Fire Drill Time	0.0s ~ 6553.5s Note: Drill cannot be started when time is set to 0.	0.0s	★	63546
P9 Group failure and protection					
P9-00	Motor overload protection selection	0: forbidden 1: allowed	1	☆	63744
P9-01	Motor overload protection gain	0.20~10.00	1.00	☆	63745
P9-02	Motor overload warning coefficient	50%~100%	80%	☆	63746
P9-03	Overvoltage stall gain	0~100	30	☆	63747
P9-04	Overvoltage stall action voltage	200.0~2000.0V 220V: 380V 380V: 760V	Model confirmed	☆	63748
P9-05	Overrun stall gain	0~100	20	☆	63749

Function code	Name	Setting range	Factory default	Attributes	DEC address
P9-06	Overcurrent stall protection current	100%~200%	150%	☆	63750
P9-07	Power-on short-circuit protection selection	0: invalid 1: valid	1	☆	63751
P9-08	Dynamic braking action voltage	200.0~2000.0V	220V: 360V 380V: 700V	☆	63752
P9-09	Fault automatic reset times	0~20	0	☆	63753
P9-10	DO action selection during fault automatic reset	0: no action 1: action	0	☆	63754
P9-11	Fault automatic reset interval time	0.1s~100.0s	1.0s	☆	63755
P9-12	Input phase loss protection selection	0: Disabled 1: Allowed	0	☆	63756
P9-13	Output phase loss protection selection	0: forbidden 1: allowed	1	☆	63757
P9-14	First failure type	0: No fault 1: Reserved 2: Acceleration overcurrent 3: Deceleration overcurrent 4: Constant speed overcurrent 5: Acceleration overvoltage 6: Deceleration overvoltage 7: Constant speed overvoltage	-	●	63758

P9-15	Second failure type	8: Reserved 9: Undervoltage 10: Inverter Overload 11: Motor overload 12: Input phase loss 13: Output phase loss 14: Module overheating 15: External fault 16: Communication abnormality 17: Reserved 18: Current detection abnormality 19: Motor tuning abnormality 20: Reserved 21: Parameter reading and writing abnormality 22: Reserved 23: Motor short circuit to ground	-	●	63759
P9-16	Third (most recent) failure type	24: Reserved 25: Reserved 26: Running time reached 27: User-defined fault 1 28: User-defined fault 2 29: Power- on time reached 30: Load off 31: PID feedback lost during running 40: Fast current limit overtime 41: Switch motor during operation 42: Excessive speed deviation 43: Motor overspeed 45: Reserved 51: Reserved 70: Lack of water pressure failure 71: Over water pressure failure	--	●	63760

Function code	Name	Setting range	Factory default	Attributes	DEC address
P9-17	The third (most recent) failure	-	-	●	63761
P9-18	The third (latest) fault	-	-	●	63762
P9-19	Bus voltage at the third (latest) fault	-	-	●	63763
P9-20	Input terminal status at the third (latest) fault	-	-	●	63764
P9-21	The third (latest) fault	-	-	●	63765
P9-22	Inverter status at the third (latest) fault	-	-	●	63766
P9-23	Power-on time at the third (most recent) failure	-	-	●	63767
P9-24	Uptime on third (most recent) failure	-	-	●	63768
P9-27	Frequency at second failure	-	-	●	63771
P9-28	Current at second fault	-	-	●	63772
P9-29	Bus voltage at second fault	-	-	●	63773
P9-30	Input terminal status at the second fault	-	-	●	63774

P9-31	Output terminal status at the second fault	-	-	●	63775
P9-32	Inverter status at the time of the second fault	-	-	●	63776
P9-33	Power-on time at the second fault	-	-	●	63777
P9-34	Run time on second failure	-	-	●	63778
P9-37	Frequency at first failure	-	-	●	63781
P9-38	Current at the first fault	-	-	●	63782
P9-39	Bus voltage at first fault	-	-	●	63783
P9-40	Input terminal status at the first fault	-	-	●	63784
P9-41	Output terminal status at the first fault	-	-	●	63785
P9-42	Inverter status at the first fault	-	-	●	63786
P9-43	Power-on time at first failure	-	-	●	63787
P9-44	Uptime to first failure	-	-	●	63788

Function code	Name	Setting range	Factory default	Attributes	DEC address
P9-47	Failsafe action selection 1	Ones place: Motor overload (11) Tens place: Input phase loss (12) Hundreds place: Output phase loss (13) Thousands place: External fault (15) Thousands place: Communication abnormality (16) 0: free stop 1: stop according to stop mode 2: continue to run	00000	☆	63791
P9-54	Continue to run frequency selection in case of failure	0: Run at the current running frequency 1: Run at the setting frequency 2: Run at the upper limit frequency 3: Run at the lower limit frequency 4: Run at the abnormal standby frequency	0	☆	63798
P9-55	Abnormal standby frequency	60.0%~100.0% (100.0% corresponds to the maximum frequency P0-10)	100.0%	☆	63799
P9-59	Instantaneous power failure action selection	0: Invalid 1: Deceleration 2: Deceleration to stop	0	●	63803
P9-60	Momentary power failure action pause judgment voltage	P9-62~100.0%	100.0%	●	63804

P9-62	Instantaneous power failure action judgment voltage	60.0%~100.0% (standard bus voltage)	80.0%	☆	63806
P9-63	Load Loss Protection Selection	0: invalid 1: valid	0	☆	63807
P9-64	Load drop detection level	0.0~100.0%	10.0%	☆	63808
P9-65	Load drop detection time	0.0~60.0s	1.0s	☆	63809
PA Group PID function					
PA-00	PID given source	0: PA-01 setting 1: AI1 2: AI2 3: AI3 external keyboard potentiometer 4: PLUSE input pulse setting (DI5) 5: Communication setting 6: Multi-segment command setting 7: Given by the pressure of water supply group b0-01	0	☆	64000
PA-01	PID value given	0.0~100.0%	50.0%	☆	64001
PA-02	PID feedback source	0: AI1 1: AI2 2: AI3 external keyboard potentiometer 3: AI1-AI2 4: PLUSE input pulse setting (DI5) 5: Communication reference 6: AI1+AI2 7: MAX (AI1 , AI2) 8: MIN (AI1 , AI2)	0	☆	64002

Function code	Name	Setting range	Factory default	Attributes	DEC address
PA-03	PID action direction	0: Positive action 1: Reverse action	0	☆	64003
PA-04	PID given feedback range	0~65535	1000	☆	64004
PA-05	Proportional gain KP1	0.0~100.0	20.0	☆	64005
PA-06	Integration time Ti1	0.01~10.00s	2.00s	☆	64006
PA-07	Derivative time Td1	0.000~10.000s	0.000s	☆	64007
PA-08	PID inversion cut-off frequency	0.00~maximum frequency	2.00Hz	☆	64008
PA-09	PID deviation limit	0.0~100.0%	0.0%	☆	64009
PA-10	PID differential limiter	0.00~100.00%	0.10%	☆	64010
PA-11	PID given change time	0.00~650.00s	0.00s	☆	64011
PA-12	PID feedback filter time	0.00~60.00s	0.00s	☆	64012
PA-13	PID output filter time	0.00~60.00s	0.00s	☆	64013
PA-15	Proportional gain KP2	0.0~100.0	20.0	☆	64015
PA-16	Integration time Ti2	0.01s~10.00s	2.00s	☆	64016
PA-17	Derivative time Td2	0.000s~10.000s	0.000s	☆	64017

PA-18	PID parameter switching condition	0: No switching 1: Switching via DI terminal 2: Automatic switching according to deviation	0	☆	64018
PA-19	PID parameter switching deviation 1	0.0%~PA-20	20.0%	☆	64019
PA-20	PID parameter switching deviation 2	PA-19~100.0%	80.0%	☆	64020
PA-21	PID initial value	0.0~100.0%	0.0%	☆	64021
PA-22	PID initial value hold time	0.00~650.00s	0.00s	☆	64022
PA-23	The maximum value of the positive direction of the two output deviations	0.00~100.00%	1.00%	☆	64023
PA-24	The reverse maximum value of the two output deviations	0.00~100.00%	1.00%	☆	64024
PA-25	PID integral attribute	Units: Integral separation 0: Invalid 1: Valid Tens: Whether to stop integration after the output reaches the limit 0: Continue integration 1: Stop integration	00	☆	64025
PA-26	PID feedback loss detection value	0.0%: no judgment feedback loss 0.1 ~ 100.0%	0.0%	☆	64026

Function code	Name	Setting range	Factory default	Attributes	DEC address
PA-27	PID feedback loss detection time	0.0s~20.0s	0.0s	☆	64027
PA-28	PID stop operation	0: no operation when shutdown 1: operation when shutdown	1	☆	64028
Pb Group swing frequency, fixed length and counting					
Pb-00	Wobble frequency setting method	0: relative to the center frequency 1: relative to the maximum frequency	0	☆	64256
Pb-01	Swing frequency	0.0~100.0%	0.0%	☆	64257
Pb-02	Jump frequency amplitude	0.0~50.0%	0.0%	☆	64258
Pb-03	Swing cycle	0.1~3000.0s	10.0s	☆	64259
Pb-04	Triangular wave rise time of wobble frequency	0.1~100.0%	50.0%	☆	64260
Pb-05	Set length	0~65535m	1000m	☆	64261
Pb-06	Actual length	0~65535m	0m	☆	64262
Pb-07	Pulses per meter	0.1~6553.5	100.0	☆	64263
Pb-08	Set count value	1~65535	1000	☆	64264
Pb-09	Specify the count value	1~65535	1000	☆	64265
PC Group multi-segment instructions and simple PLC					
PC-00	Multi-segment instruction 0	-100.0%~100.0%	0.0%	☆	64512

PC-01	Multi-segment instruction 1	-100.0%~100.0%	0.0%	☆	64513
PC-02	Multi-segment instruction 2	-100.0%~100.0%	0.0%	☆	64514
PC-03	Multi-stage instruction 3	-100.0%~100.0%	0.0%	☆	64515
PC-04	Multi-segment instruction 4	-100.0%~100.0%	0.0%	☆	64516
PC-05	Multi-segment instruction 5	-100.0%~100.0%	0.0%	☆	64517
PC-06	Multi-segment instruction 6	-100.0%~100.0%	0.0%	☆	64518
PC-07	Multi-segment instruction 7	-100.0%~100.0%	0.0%	☆	64519
PC-08	Multi-segment instructions 8	-100.0%~100.0%	0.0%	☆	64520
PC-09	Multi-segment instructions 9	-100.0%~100.0%	0.0%	☆	64521
PC-10	Multi-segment instructions 10	-100.0%~100.0%	0.0%	☆	64522
PC-11	Multi-segment instructions 11	-100.0%~100.0%	0.0%	☆	64523
PC-12	Multi-segment instruction 12	-100.0%~100.0%	0.0%	☆	64524
PC-13	Multi-stage instruction 13	-100.0%~100.0%	0.0%	☆	64525
PC-14	Multi-segment instructions 14	-100.0%~100.0%	0.0%	☆	64526
PC-15	Multi-segment instruction 15	-100.0%~100.0%	0.0%	☆	64527
PC-16	Simple PLC operation mode	0: Stop at the end of a single operation 1: Keep the final value at the end of a single operation 2: Always cycle	0	☆	64528

Function code	Name	Setting range	Factory default	Attributes	DEC address
PC-17	Easy PLC power-down memory selection	Units: power-off memory selection 0: power -off no memory 1: power-off memory ten's place: stop memory selection 0: stop no memory 1: stop memory	00	☆	64529
PC-18	Simple PLC 0 segment running time	0.0s (h) ~ 6553.5s (h)	0.0s(h)	☆	64530
PC-19	Simple PLC 0 segment Acceleration and deceleration time selection	0~3	0	☆	64531
PC-20	Simple PLC 1 stage running time	0.0s (h) ~ 6553.5s (h)	0.0s(h)	☆	64532
PC-21	Simple PLC 1 stage Acceleration and deceleration time selection	0~3	0	☆	64533
PC-22	Simple PLC 2-stage running time	0.0s (h) ~ 6553.5s (h)	0.0s(h)	☆	64534
PC-23	Simple PLC 2-segment Acceleration and deceleration time selection	0~3	0	☆	64535

PC-24	Simple PLC 3-segment running time	0.0s (h) ~ 6553.5s (h)	0.0s(h)	☆	64536
PC-25	Simple PLC 3-segment Acceleration and deceleration time selection	0~3	0	☆	64537
PC-26	Simple PLC 4-segment running time	0.0s (h) ~ 6553.5s (h)	0.0s(h)	☆	64538
PC-27	Simple PLC 4 segments Acceleration and deceleration time selection	0~3	0	☆	64539
PC-28	Simple PLC 5-segment running time	0.0s (h) ~ 6553.5s (h)	0.0s(h)	☆	64540
PC-29	Simple PLC 5 segments Acceleration and deceleration time selection	0~3	0	☆	64541
PC-30	Simple PLC 6-segment running time	0.0s (h) ~ 6553.5s (h)	0.0s(h)	☆	64542
PC-31	Simple PLC 6-segment Acceleration and deceleration time selection	0~3	0	☆	64543
PC-32	Simple PLC 7-segment running time	0.0s (h) ~ 6553.5s (h)	0.0s(h)	☆	64544

Function code	Name	Setting range	Factory default	Attributes	DEC address
PC-33	Simple PLC 7-segment Acceleration and deceleration time selection	0~3	0	☆	64545
PC-34	Simple PLC 8-segment running time	0.0s (h) ~ 6553.5s (h)	0.0s(h)	☆	64546
PC-35	Simple PLC 8 segments Acceleration and deceleration time selection	0~3	0	☆	64547
PC-36	Simple PLC 9-segment running time	0.0s (h) ~ 6553.5s (h)	0.0s(h)	☆	64548
PC-37	Simple PLC 9 segments Acceleration and deceleration time selection	0~3	0	☆	64549
PC-38	Simple PLC 10-segment running time	0.0s (h) ~ 6553.5s (h)	0.0s(h)	☆	64550
PC-39	Simple PLC 10 segments Acceleration and deceleration time selection	0~3	0	☆	64551
PC-40	Simple PLC 11-segment running time	0.0s (h) ~ 6553.5s (h)	0.0s(h)	☆	64552

PC-41	Simple PLC 11 segments Acceleration and deceleration time selection	0~3	0	☆	64553
PC-42	Simple PLC 12-segment running time	0.0s (h) ~ 6553.5s (h)	0.0s(h)	☆	64554
PC-43	Simple PLC 12 segments Acceleration and deceleration time selection	0~3	0	☆	64555
PC-44	Simple PLC 13 segment running time	0.0s (h) ~ 6553.5s (h)	0.0s(h)	☆	64556
PC-45	Simple PLC 13 segments Acceleration and deceleration time selection	0~3	0	☆	64557
PC-46	Simple PLC 14 segment running time	0.0s (h) ~ 6553.5s (h)	0.0s(h)	☆	64558
PC-47	Simple PLC 14 segments Acceleration and deceleration time selection	0~3	0	☆	64559
PC-48	Simple PLC 15 segment running time	0.0s (h) ~ 6553.5s (h)	0.0s(h)	☆	64560

Function code	Name	Setting range	Factory default	Attributes	DEC address
PC-49	Simple PLC 15 segments Acceleration and deceleration time selection	0~3	0	☆	64561
PC-50	Simple PLC operation time unit	0: s (second) 1: h (hour)	0	☆	64562
PC-51	Multi-segment instruction 0 given mode	0: Function code PC-00 setting 1: AI1 2: AI2 3: AI3 external keyboard potentiometer 4: PLUSE input pulse 5: PID 6: Preset frequency (P0-08) setting , UP/DOWN can be modified	0	☆	64563
Pd Group communication parameters					
Pd-00	Baud rate	0: 300BPS 1: 600BPS 2: 1200BPS 3: 2400BPS 4: 4800BPS 5: 9600BPS 6: 19200BPS 7: 38400BPS 8: 57600BPS	5	☆	64768
Pd-01	Data Format	0: No parity (8-N-2) 1: Even parity (8-E-1) 2: Odd parity (8-O-1) 3: No parity (8-N-1)	3	☆	64769
Pd-02	Local address	1~247	1	☆	64770

Pd-02	Local address	1~247	1	☆	64770
Pd-03	Response delay	0~20ms	2	☆	64771
Pd-04	Communication timeout	0.0(invalid), 0.1s~60.0s	0.0	☆	64772
Pd-05	Data transfer format selection	1: Standard MODBUS protocol	1	☆	64773
Pd-06	Communication reading current resolution	0: 0.01A 1: 0.1A	0	☆	64774
Pd-07	Reserve	-	0	☆	64775
PP Group user password					
PP-00	User password	0~65535	00000	☆	7936
PP-01	Parameter initialization	0: No operation 01: Restore factory parameters, excluding motor parameters 02: Clear record information 03: restore factory parameters, including motor parameters 04: reserved	000	★	7937
PP-02	Function parameter group display selection	Group U display selection Tens: Group A display selection Hundreds place: group b display selection 0: no display 1: display	111	★	7938
PP-04	Function ode to modify attributes	0: Can be modified 1: Cannot be modified	0	☆	7940
Group A0 torque control parameters					

Function code	Name	Setting range	Factory default	Attributes	DEC address
A0-00	Speed/torque selection	0: speed control 1: Torque control	0	☆	40960
A0-01	Torque setting source	0: A0-03 setting 1: AI1 setting 2: AI2 setting 3: AI3 keyboard potentiometer setting 4: HDI high speed pulse setting 5: Communication setting 6: MIN(AI1, AI2) 7: MAX(AI1, AI2) Note: 1-7 full scale corresponds to A0-03 digital setting	0	★	40961
A0-02	Reserve	-	-	-	-
A0-03	Torque digital setting	-200.0%~200.0%	150.0%	☆	40963
A0-04	Reserve	-	-	-	-
A0-05	Torque positive maximum frequency	0.00Hz~maximum frequency (P0-10)	50.00Hz	☆	40965
A0-06	Torque reverse maximum frequency	0.00Hz~maximum frequency (P0-10)	50.00Hz	☆	40966
A0-07	Torque acceleration time	0~655.35s	0.00s	☆	40967
A0-08	Torque deceleration time	0~655.35s	0.00s	☆	40968
Group A5 control optimization parameters					

A5-00	DPWM switching upper limit frequency	0.00Hz~15.00Hz	12.00Hz	☆	42240
A5-01	PWM modulation method	0: Asynchronous modulation 1: Synchronous modulation	0	☆	42241
A5-02	Dead zone compensation mode selection	0: No compensation 1: Compensation mode 1 2: Compensation mode 2	1	☆	42242
A5-03	Random PWM Depth	0: Random PWM invalid 1 ~ 10: PWM carrier frequency random depth	0	☆	42243
A5-04	Fast current limit enable	0: Disable 1: Enable	1	☆	42244
A5-05	Current Sense Compensation	0~100	5	☆	42245
A5-06	Undervoltage point setting	100.0~2000.0V	Model	☆	42246
A5-07	SVC optimization mode selection	0: no optimization 1: optimization mode 1 2: optimization mode 2	1	☆	42247
A5-08	Dead time adjustment	100~200%	150%	☆	42248
A5-09	Overvoltage point setting	200.0~2500.0V	Model	★	42249
Group AC AIAO correction					
AC-00	AI1 measured voltage 1	0.500V~4.000V	Factory correction	☆	44032
AC-01	AI1 display voltage 1	0.500V~4.000V	Factory correction	☆	44032
AC-02	AI1 measured voltage 2	6.000V~9.999V	Factory correction	☆	44034

Function code	Name	Setting range	Factory default	Attributes	DEC address
AC-03	AI1 measured voltage 2	6.000V~9.999V	Factory correction	☆	44035
AC-04	AI2 measured voltage 1	0.500V~4.000V	Factory correction	☆	44036
AC-05	AI2 display voltage 1	0.500V~4.000V	Factory correction	☆	44037
AC-06	AI2 measured voltage 2	6.000V~9.999V	Factory correction	☆	44038
AC-07	AI2 measured voltage 2	6.000V~9.999V	Factory correction	☆	44039
AC-08	AI3 measured voltage 1	0.500V~4.000V	Factory correction	☆	44040
AC-09	AI3 display voltage 1	0.500V~4.000V	Factory correction	☆	44041
AC-10	AI3 measured voltage 2	6.000V~9.999V	Factory correction	☆	44048
AC-11	AI3 measured voltage 2	6.000V~9.999V	Factory correction	☆	44049
AC-12	AO1 target voltage 1	0.500V~4.000V	Factory correction	☆	44050
AC-13	AO1 measured voltage 1	0.500V~4.000V	Factory correction	☆	44051
AC-14	AO1 target voltage 2	6.000V~9.999V	Factory correction	☆	44052
AC-15	AO1 measured voltage 2	6.000V~9.999V	Factory correction	☆	44053
AC-16	AO2 target voltage 1	0.500V~4.000V	Factory correction	☆	44054

AC-17	AO2 measured voltage 1	0.500V~4.000V	Factory correction	☆	44055
AC-18	AO2 target voltage 2	6.000V~9.999V	Factory correction	☆	44056
AC-19	AO2 measured voltage 2	6.000V~9.999V	Factory correction	☆	44057
AC-20	AI2 measured current 1	0.000mA~20.000mA	Factory correction	☆	44064
AC-21	AI2 sampling current 1	0.000mA~20.000mA	Factory correction	☆	44065
AC-22	AI2 measured current 2	0.000mA~20.000mA	Factory correction	☆	44066
AC-23	AI2 sampling current 2	0.000mA~20.000mA	Factory correction	☆	44067
AC-24	AO1 ideal current 1	0.000mA~20.000mA	Factory correction	☆	44068
AC-25	AO1 measured current 1	0.000mA~20.000mA	Factory correction	☆	44069
AC-26	AO1 ideal current 2	0.000mA~20.000mA	Factory correction	☆	44070
AC-27	AO1 measured current 2	0.000mA~20.000mA	Factory correction	☆	44071
B0 group intelligent constant pressure water supply parameter table					
b0-00	Pressure sensor range	0~99.99Bar (kg)	10.0 0	☆	45056

Function code	Name	Setting range	Factory default	Attributes	DEC address
b0-01	Target pressure figure given Note: The target pressure is selected by PA-01	0~99.99Bar (kg)	5.0 0	☆	45057
b0-02	Dormant pressure	0~100.0%(linked with target pressure ratio)	10.0%	☆	45058
b0-03	Wake up stress	0~100.0% (linked with target pressure ratio)	95.0%	☆	45059
b0-04	Pressure stability deviation	0~100.0% (linked with target pressure ratio)	2.0%	☆	45060
b0-05	Sleep delay	0~6553.5s (0: disable sleep)	20.0 s	☆	45061
b0-06	Wake up delay	0~6553.5s	0.0 s	☆	45062
b0-07	Pressure upper limit protection value	0~200.0% (linked with the target pressure ratio)	110.0%	☆	45063
b0-08	Pressure upper limit protection shutdown delay	0~6553.5s(0:close detection)	0.3s	☆	45064
b0-09	Lower limit frequency exceeds target pressure protection delay	0~6553.5s(0:close detection)	3.0s	☆	45065
b0-10	Auxiliary pump quantity setting	0~4 (0: turn off one drag and more)	0	☆	45066

b0-11	Plus auxiliary pump pressure tolerance	0~100.0% (linked with target pressure ratio)	5.0%	☆	45067
b0-12	Add auxiliary pump delay	0~6553.5s	30.0s	☆	45068
b0-13	Minus auxiliary pump pressure tolerance	0~100.0% (linked with target pressure ratio)	5.0%	☆	45069
b0-14	Subtract auxiliary pump delay	0~6553.5s	30.0 s	☆	45070
b0-15	Pressure upper limit emergency reduction auxiliary pump delay (Preempt the normal pump down time of b0-14)	0 ~ 6553.5s	3.0 s	☆	45071
b0-16	Water shortage protection pressure	0~100.0% (linked with target pressure ratio) Note: Start detection when the frequency exceeds the upper limit	20.0%	☆	45072
b0-17	Water shortage protection delay	0~6553.5s (0: Disable detection)	0.0s	☆	45073
b0-18	sleep mode selection	0: disable sleep 1: pressure sleep (feedback pressure \geq b0-02) 2: Frequency sleep (output frequency \leq b0-19) 3: Dormancy pressure (b0-02) + dormancy frequency (b0-19)	3	★	45074

Function code	Name	Setting range	Factory default	Attributes	DEC address
b0-19	Sleep detection frequency	0.00Hz~maximum frequency (P0-10) Note: only valid for b0-18=2	20.00Hz	☆	45075
b0-20	Selection of pressure protection mode	00~11 Units: overpressure upper limit protection (b0-07) Tens place: water shortage and pressure protection (b0-16) 0: no fault report 1: report failure Note: Undervoltage fault Err70, overvoltage fault Err71	00	★	45076
U0 group parameter monitoring group					
U0-00	Operating frequency (Hz)	-	0.01Hz	●	28672
U0-01	Set frequency (Hz)	-	0.01Hz	●	28673
U0-02	Bus voltage (V)	-	0.1V	●	28674
U0-03	Output voltage (V)	-	1V	●	28675
U0-04	Output current (A)	-	0.01A	●	28676
U0-05	Output power (kW)	-	0.1kW	●	28677
U0-06	Output torque (%)	-	0.1%	●	28678
U0-07	DI input state	-	1	●	28679
U0-08	FM output status	-	1	●	28680

U0-09	AI1 voltage (V)	-	0.01V	●	28681
U0-10	AI2 voltage (V)	-	0.01V	●	28682
U0-11	AI3 panel potentiometer voltage	-	0.01V	●	28683
U0-12	Count value	-	1	●	28684
U0-13	Length value	-	1	●	28685
U0-14	Load speed display	-	1	●	28686
U0-15	PID setting (dimensionless) PID set pressure value (water supply activated)	-	1 0.01kg	●	28687
U0-16	PID feedback (dimensionless) PID feedback pressure value (water supply activated)	-	1 0.01kg	●	28688
U0-17	PLC stage	-	1	●	28689
U0-18	PLUSE input pulse frequency (Hz)	-	0.01kHz	●	28690
U0-19	Feedback speed (unit 0.1Hz)	-	0.1Hz	●	28691
U0-20	Remaining run time	-	0.1Min	●	28692
U0-21	AI1 voltage before correction	-	0.001V	●	28693

Function code	Name	Setting range	Factory default	Attributes	DEC address
U0-22	AI2 voltage before correction	-	0.001V	●	28694
U0-23	Voltage before panel potentiometer correction	-	0.001V	●	28695
U0-24	Line speed	-	1m/Min	●	28696
U0-25	Current power-on time	-	1Min	●	28697
U0-26	Current running time	-	0.1Min	●	28698
U0-27	PLUSE input pulse frequency	-	1Hz	●	28699
U0-28	Communication settings	-	0.01%	●	28700
U0-30	Main frequency X display	-	0.01Hz	●	28702
U0-31	Auxiliary frequency Y display	-	0.01Hz	●	28703
U0-32	View any memory address value	-	1	●	28704
U0-35	Target torque (%)	-	0.1%	●	28707
U0-36	Current number of working auxiliary pumps	-	0	●	28708
U0-37	Power factor angle	-	0.1°	●	28709

U0-39	Reserve	-	1V	●	28711
U0-40	Reserve	-	1V	●	28712
U0-41	Visual display of DI input status	-	1	●	28713
U0-42	Visual display of FM input status	-	1	●	28714
U0-43	Visual display of DI function status 1	-	1	●	28715
U0-44	Visual display of DI function status 2	-	1	●	28716
U0-45	Accident details	-	1	●	28717
U0-59	Set frequency (%)	-	0.01%	●	28731
U0-60	Operating frequency (%)	-	0.01%	●	28732
U0-61	Inverter status	-	1	●	28733
U0-62	Current fault code	-	1	●	28734
U0-65	Torque upper limit	-	0.1%	●	28737
U0-66	U phase current display (A)	-	0.01A	●	28738
U0-67	V phase current display (A)	-	0.01A	●	28739
U0-68	W phase current display (A)	-	0.01A	●	28740

Chapter 7 Troubleshooting and Maintenance

7.1 Troubleshooting

7.1.1 Handle failure

When the inverter fails, a fault alarm display screen will appear on the operation panel, and the fault relay will act at the same time, the inverter will stop output, and the motor will stop freely.

After a fault alarm occurs, record the fault phenomenon in detail, and refer to Table 7-1 to troubleshoot and clear.

Table 7-1 Fault Alarm Contents and Countermeasures

Fault name	Fault Code	Troubleshooting	Troubleshooting Countermeasures
Inverter unit protection	Err01	<ol style="list-style-type: none"> 1. The inverter output circuit is shortcircuited 2. The wiring between the motor and the inverter is too long 3. The module is overheated 4. The internal wiring of the inverter is loose 5. The main control board is abnormal 6. The driver board is abnormal 7. The inverter module is abnormal 	<ol style="list-style-type: none"> 1. Eliminate peripheral faults 2. Install reactor or output filter 3. Check whether the air duct is blocked and whether the fan is working properly. work normally and troubleshoot 4. Plug in all cables 5. Seek technical support 6. Seek technical support 7. Seek technical support
Acceleration overcurrent	Err02	<ol style="list-style-type: none"> 1. There is grounding or short circuit in the output circuit of the inverter 2. The control mode is vector without parameter identification 3. The acceleration time is too short 4. Manual torque boost or V/F curve is inappropriate 5. Low voltage 6. Start the rotating motor 7. Sudden load increase during acceleration 	<ol style="list-style-type: none"> 1. Eliminate peripheral faults 2. Carry out motor parameter identification 3. Increase the acceleration time 4. Adjust manual lifting torque or V/F curve 5. Adjust the voltage to the normal range 6. Select the speed tracking start or wait for the motor to stop restart 7. Cancel sudden load

		8. The selection of Frequency Inverter is too small	8. Choose a Frequency Inverter with a higher power level
Deceleration overcurrent	Err03	<ol style="list-style-type: none"> 1. There is grounding or short circuit in the output circuit of the inverter 2. The control mode is vector without parameter identification 3. The deceleration time is too short 4. Low voltage 5. Sudden load increase during deceleration 6. No braking unit and braking resistor installed 	<ol style="list-style-type: none"> 1. Eliminate peripheral faults 2. Carry out motor parameter identification 3. Increase the deceleration time 4. Adjust the voltage to the normal range 5. Cancel sudden load 6. Install brake unit and resistor
Constant speed overcurrent	Err04	<ol style="list-style-type: none"> 1. There is grounding or short circuit in the output circuit of the inverter 2. The control mode is vector without parameter identification 3. Low voltage 4. Whether there is a sudden load during operation 5. The selection of Frequency inverter is too small 	<ol style="list-style-type: none"> 1. Eliminate peripheral faults 2. Carry out motor parameter identification 3. Adjust the voltage to the normal range 4. Cancel the sudden load 5. Choose a Frequency Inverter with a higher power level
Accelerated overvoltage	Err05	<ol style="list-style-type: none"> 1. The input voltage is too high 2. During the acceleration process, there is an external force to drive the motor to run 3. Acceleration time is too short 4. No braking unit and braking resistor installed 	<ol style="list-style-type: none"> 1. Adjust the voltage to the normal range 2. Cancel the external power or install braking resistor 3. Increase the acceleration time 4. Install brake unit and resistor

Fault name	Fault Code	Troubleshooting	Troubleshooting Countermeasures
Deceleration overvoltage	Err06	1. The input voltage is too high 2. During the acceleration process, there is an external force to drive the motor to run 3. The deceleration time is too short 4. No braking unit and braking resistor installed	1. Adjust the voltage to the normal range 2. Cancel the external power or install braking resistor 3. Increase the acceleration time 4. Install brake unit and resistor
Constant speed overvoltage	Err07	1. The input voltage is too high 2. There is an external force to drive the motor during operation	1. Adjust the voltage to the normal range 2. Cancel the external power or install braking resistor
Control power failure	Err08	1. The input voltage is not within the specified range	1. Adjust the voltage to the range required by the specification
Undervoltage fault	Err09	1. Momentary power failure 2. The input voltage of the inverter is not within the range required by the specification 3. The bus voltage is abnormal 4. The rectifier bridge and buffer resistor are abnormal 5. The driver board is abnormal 6. The control panel is abnormal	1. Reset fault 2. Adjust the voltage to the normal range 3. Seek technical support 4. Seek technical support 5. Seek technical support 6. Seek technical support
Inverter overload	Err10	1. Whether the load is too large or the motor is blocked 2. The selection of Frequency Inverter is too small	1. Reduce the load and check the motor and mechanical condition 2. Choose a Frequency Inverter with a higher power level

Motor overload	Err11	<ol style="list-style-type: none"> Whether the setting of motor protection parameter P9-01 is appropriate Whether the load is too large or the motor is blocked The selection of Frequency Inverter is too small 	<ol style="list-style-type: none"> Set this parameter correctly Reduce the load and check the motor and mechanical condition Select a Frequency Inverter with a higher power level
Input phase loss	Err12	<ol style="list-style-type: none"> The three-phase input power supply is abnormal The driver board is abnormal Abnormal lightning protection board The main control board is abnormal 	<ol style="list-style-type: none"> Check and eliminate the problems in the peripheral circuit Seek technical support Seek technical support Seek technical support
Output phase loss	Err13	<ol style="list-style-type: none"> The lead wire from the inverter to the motor is abnormal The three-phase output of the inverter is unbalanced when the motor is running The driver board is abnormal Module exception 	<ol style="list-style-type: none"> Eliminate peripheral faults Check whether the three-phase winding of the motor is normal and troubleshoot Seek technical support Seek technical support
Module overheating	Err14	<ol style="list-style-type: none"> The ambient temperature is too high The air duct is blocked The fan is damaged The module thermistor is damaged The inverter module is damaged 	<ol style="list-style-type: none"> Reduce the ambient temperature Clean the air duct Replace the fan Replace the thermistor Replace the inverter module
External device Fault	Err15	<ol style="list-style-type: none"> Multi-function terminal X inputs external fault signal The virtual IO function inputs an external fault signal 	<ol style="list-style-type: none"> Reset operation Reset operation

Fault name	Fault Code	Troubleshooting	Troubleshooting Countermeasures
Communication fail	Err16	1. The upper computer is not working properly 2. The communication line is abnormal 3. Reserve 4. The setting of the communication parameter PD group is incorrect	1. Check the wiring of the host computer 2. Check the communication cable 3. Correctly set the communication expansion card type 4. Correctly set the communication parameters
Current sense failure	Err18	1. Check the abnormality of the Hall device 2. The driver board is abnormal	1. Replace the Hall device 2. Replace the driver board
Motor tuning failure	Err19	1. The motor parameters are not set according to the nameplate 2. The parameter identification process timed out	1. Correctly set the motor parameters according to the nameplate 2. Check the lead wires from the inverter to the motor
EEPROM Read and write failure	Err21	1. The EEPROM chip is damaged	1. Replace the main control board
Inverter hardware failure	Err22	1. There is overvoltage 2. There is an overcurrent	1. Handle according to overvoltage fault 2. Handle according to overcurrent fault
Short circuit fault to ground	Err23	1. The motor is short-circuited to the ground	1. Replace the cable or motor
Cumulative running time reached fault	Err26	1. The cumulative running time reaches the set value	1. Use the parameter initialization function to clear the record information
Custom Fault 1	Err27	1. Input the signal of user-defined fault 1 through the multi-function terminal X 2. Input the signal of user-defined fault 1 through the virtual IO function	1. Reset operation 2. Reset operation

Custom failure 2	Err28	<ol style="list-style-type: none"> 1. Input the signal of user-defined fault 2 through the multi-function terminal X 2. Input the signal of user-defined fault 2 through the virtual IO function 	<ol style="list-style-type: none"> 1. Reset operation 2. Reset operation
Cumulative power-on time reached fault	Err29	<ol style="list-style-type: none"> 1. The cumulative power-on time reaches the set value 	<ol style="list-style-type: none"> 1. Use the parameter initialization function to clear the record information
Load drop fault	Err30	<ol style="list-style-type: none"> 1. The operating current of the inverter is less than P9-64 	<ol style="list-style-type: none"> 1. Confirm whether the load is off or whether the parameter settings of P9-64 and P9-65 conform to the actual operating conditions
PID feedback lost at runtime Fault	Err31	<ol style="list-style-type: none"> 1. PID feedback is less than the set value of PA-26 	<ol style="list-style-type: none"> 1. Check the PID feedback signal or set PA-26 to an appropriate value
Wave-by-wave current limiting fault	Err40	<ol style="list-style-type: none"> 1. Whether the load is too large or the motor is blocked 2. The selection of Frequency Inverter is too small 	<ol style="list-style-type: none"> 1. Reduce the load and check the motor and mechanical condition 2. Choose a Frequency Inverter with a higher power level
Switching motor failure while running	Err41	<ol style="list-style-type: none"> 1. Change through the terminals during the operation of the inverter Current motor selection 	<ol style="list-style-type: none"> 1. Switch the motor after the inverter stops
Motor over temperature fault	Err45	<ol style="list-style-type: none"> 1. The wiring of the temperature sensor is loose 2. The temperature of the motor is too high 	<ol style="list-style-type: none"> 1. Check the wiring of the temperature sensor and troubleshoot 2. Reduce the carrier frequency or take other heat dissipation measures to dissipate heat from the motor

Fault name	Fault Code	Troubleshooting	Troubleshooting Countermeasures
Wrong initial position	Err51	1. The motor parameters and the actual deviation are too large	1. Reconfirm whether the motor parameters are correct, focusing on whether the rated current is set too small
Water shortage protection	Err70	1. The on-site water pressure is lower than the set water shortage protection pressure of b0-16	1. Check whether the set value of b0-16 is reasonable 2. Whether the water pipe is burst 3. Is the water pump damaged
Excess water pressure protection	Err71	The on-site water pressure is higher than the set pressure value of b0-07	1. Check whether the set value of b0-07 is reasonable 2. Is the outlet valve closed 3. Whether the pressure sensor is damaged

7.2 Maintenance

Due to the influence of environmental temperature, humidity, pH, dust, vibration and other factors, as well as many reasons such as the aging and wear of the components inside the Frequency Inverter, potential failures will occur. Therefore, the controller must be routinely checked during storage and use. or regular maintenance.

- If the inverter has been transported for a long distance, it should be routinely inspected before use to confirm that the product components are complete and the screws are fastened.
- During the use of the inverter, the dust inside the inverter should be cleaned regularly, and the internal fastening screws should be checked to make sure that there is no looseness.

⚠ Danger

- Only professionally trained and authorized qualified professionals can maintain the FC200.
- Maintenance personnel must remove metal ornaments before maintenance. Insulation-compliant clothing and tools must be used for maintenance.
- FC200 has dangerous high voltage inside when it is electrified and running.
- Before checking and maintaining FC200, disconnect the input power reliably and wait for at least 10 minutes. After confirming that the charging indicator light inside the FC200 is off and the voltage between the power terminals (+) and (-) is lower than 36V, the FC200 cover can be opened for maintenance.

⚠ Warn

- For inverter that have been stored for more than 2 years, when they are powered on for the first time, they should be powered up slowly through a voltage regulator.
- Do not leave wires, tools, screws and other metal objects inside the inverter.
- Do not modify the inverter without authorization.
- There are static-sensitive IC components inside the inverter, please do not touch the components on the board directly.

Daily maintenance

The FC200 must be operated in a specified environment, see section 3.2.9.

Please do the daily maintenance according to Table 7-2, so as to detect abnormal phenomena in time and prolong the service life of FC200.

Table 7-2 Daily Inspection Items

Inspection object	Check content	Judgment criteria
Operating environment	Temperature humidity	10-+40°C , 40-50°C needs derating Less than 95%RH, no condensation
	Dust, water and drip	No conductive dust accumulation, no trace of water leakage
	Gas	Odorless

Inspection object	Check content	Judgment criteria
Inverter	Vibration, heat	Stable vibration and reasonable wind temperature
	Noise	No abnormal sound
Motor	Fever	Fever without abnormality
	Noise	Uniform noise
Running state parameters	Output current	In the rated range
	The output voltage	In the rated range

Regular maintenance

According to the use environment, the user can conduct a regular routine inspection of FC200 within 3-6 months to eliminate potential failures and ensure long-term high-performance and stable operation of the equipment.

The inspection contents are:

- Control terminal screw is not loose, if it is loose, tighten it with a screw batch with appropriate torque and size ;
- The power terminals are firmly in contact, and there is no trace of overheating at the copper bar or cable connection;
- Whether the power cables and control cables are damaged, especially if there is no cut on the skin in contact with the metal surface;
- The wire lug insulation bandages of power cables and control signal wires do not fall off or break;
- It is best to use a vacuum cleaner to clean the dust on the circuit board and air duct comprehensively.

Notice:

1. The inverter has passed the withstand voltage test before leaving the factory, and the user does not need to carry out the withstand voltage test, otherwise the inverter will be damaged if the test is not done properly.
2. When conducting an insulation test on the motor, the U/V/W terminals of the inverter must be disconnected, and the motor is tested separately, otherwise the inverter will be damaged.
3. Inverter stored for a long time must undergo a power-on test within 2 years. Use a voltage regulator to slowly increase the input voltage of the inverter to the rated value, and power on for at least 5 hours.

Replacement of wearing parts

Vulnerable parts of the inverter mainly include cooling fan and filter electrolytic capacitor. Their service life is closely related to the environment of use and maintenance status. Users can set the replacement period according to the running time.

Inspection object	Cooling fan	Filter electrolytic capacitor
Life time	60,000 hours	50,000 hours
Possible cause of damage	Bearing wear, blade aging	The ambient temperature is high, frequent load jumps cause the pulsating current to increase, and the electrolyte is aging
Criterion	When the inverter is powered off, check whether there are cracks in the fan blades, etc.; when the drive is powered on, check whether the fan is running normally, whether there is abnormal vibration, noise, etc.	Whether the Frequency Inverter often has overcurrent, overvoltage and other faults when it is running under load; whether there is liquid leakage, whether the safety valve has protruded, the measurement of electrostatic capacitance, and the measurement of insulation resistance.

Disposal

When scrapping , please note:

- The electrolytic capacitor inside the inverter may explode if burned.
- Toxic gases are produced when plastic parts are incinerated.
- Please dispose of it as industrial waste.

Chapter 8 Accessories Selection

8.1 Operator panel mounting kit

The installation components of the operation panel include: the external lead installation base and the external lead extension cable.

External mounting base

The external mounting base of the operation panel is an optional accessory, please order separately if necessary.

The dimensions of the installation base are shown in Figure 8-1 , and the unit is mm.

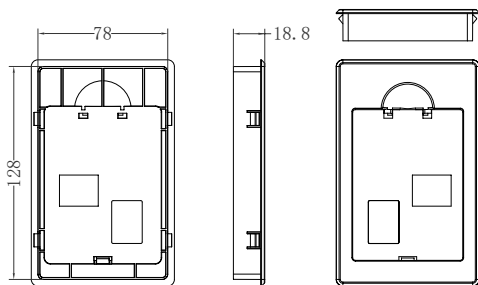

Figure 8-1 The size of the external lead installation base

External extension cable

The external extension cable of the operation panel is an optional accessory, please order separately if necessary.

The models are as follows:

- 1.5 m extension cable from the operation panel
- 5 m extension cable from the operation panel

8.2 Selection of braking unit and braking resistor

8.2.1 Selection of resistance value

During braking, almost all the regenerative energy of the motor is consumed on the braking resistor.

According to the formula:

$U^*U/R=PbU$ ---- braking voltage for stable braking of the system (different systems are different, for 380VAC system, generally take 700V)

Pb ---- braking power

8.2.2 Power Selection of Braking Resistor

Braking Resistor Theoretically, the power of the braking resistor is the same as the braking power,

but the derating is 70%. According to the formula:

$$0.7 * Pr = Pb * D$$

Pr ---- the power of the resistor

D ---- braking frequency (the regeneration process accounts for the proportion of the whole working process), generally take 10%.

Table 8-1 Braking unit and braking resistor selection recommendation table

Model	Adapted motor	Recommended Brake unit	Recommended Brake Resistor	
			Resistance	Minimum power
FC200-2S-0.4GB	0.4kW	Built-in standard	200~300Ω	50W
FC200-2S-0.75GB	0.75kW	Built-in standard	150~250Ω	100W
FC200-2S-1.5GB	1.5kW	Built-in standard	100~150Ω	200W
FC200-2S-2.2GB	2.2kW	Built-in standard	80~100Ω	250W
FC200-2S-4.0GB	4.0kW	Built-in standard	60~80Ω	400W
FC200-2S-5.5GB	5.5kW	Built-in standard	40~50Ω	600W
FC200-2S-7.5GB	7.5kW	Built-in standard	30~40Ω	800W
FC200-2S-11G(B)	11kW	Built-in standard	20~25Ω	1.2kW
FC200-2S-15G(B)	15kW	Built-in standard	15~20Ω	1.5kW
FC200-4T-0.75GB/1.5PB	0.75kW	Built-in standard	250~350Ω	100W
FC200-4T-1.5GB/2.2PB	1.5kW	Built-in standard	200~300Ω	200W
FC200-4T-2.2GB/4.0PB	2.2kW	Built-in standard	150~250Ω	250W
FC200-4T-4.0GB/5.5PB	4.0kW	Built-in standard	100~150Ω	400W
FC200-4T-5.5GB/7.5PB	5.5kW	Built-in standard	80~100Ω	600W
FC200-4T-7.5GB/11PB	7.5kW	Built-in standard	60~80Ω	800W
FC200-4T-11GB/15PB	11kW	Built-in standard	40~50Ω	1.2kW
FC200-4T-15GB/18.5PB	15kW	Built-in standard	30~40Ω	1.5kW
FC200-4T-18.5GB/22PB	18.5kW	Built-in standard	25~30Ω	2kW

Model	Adapted motor	Recommended Brake unit	Recommended Brake Resistor	
			Resistance	Minimum power
FC200-4T-22GB/30PB	22kW	Built-in standard	20~25Ω	2.5kW
FC200-4T-30G(B)/37P(B)	30kW	Built-in optional	15~20Ω	3kW
FC200-4T-37G(B)	37kW	Built-in optional	15~20Ω	4kW
FC200-4T-45G(B)/55P(B)	45kW	Built-in optional	10~15Ω	4.5kW
FC200-4T-55G(B)	55kW	Built-in optional	10~15Ω	5.5kW
FC200-4T-75G(B)/90P(B)	75kW	External	8~10Ω	7.5kW
FC200-4T-90G/110P	90kW	External	8~10Ω	9kW
FC200-4T-110G/132P	110kW	External	6~8Ω	11kW
FC200-4T-132G/160P	132kW	External	6~8Ω	13.2kW
FC200-4T-160G/185P	160kW	External	4~6Ω	16kW
FC200-4T-185G	185kW	External	4~6Ω	18kW
FC200-4T-200G/220P	200kW	External	4~6Ω	20kW
FC200-4T-220G/250P	220kW	External	4-6Ω*2	11kW*2
FC200-4T-250G/280P	250kW	External	4-6Ω*2	13kW*2
FC200-4T-280G/315P	280kW	External	4-6Ω*2	14kW*2
FC200-4T-315G/355P	315kW	External	4-6Ω*2	16kW*2
FC200-4T-355G/400P	355kW	External	4-6Ω*3	11kW*3
FC200-4T-400G/450P	400kW	External	4-6Ω*3	14kW*3
FC200-4T-450G	450kW	External	4-6Ω*3	14kW*3

Tip: *2, *3 refers to 2, 3 parallel connection.

Notice:

1.It is recommended to select the braking resistor according to the resistance value range recommended in the table above.

2.A larger resistance value can ensure safety when the braking system fails, but if the resistance value is too high, the braking ability will decrease, which may cause the inverter to have overvoltage protection.

3.Please install the braking resistor in a well-ventilated metal cover. The temperature of the braking resistor is very high when it is working. Do not directly.

Appendix A MODBUS Communication Protocol

The inverter provides RS485 communication interface and supports Modbus-RTU communication protocol. Users can realize centralized control through a computer or PLC, set inverter operation commands through this communication protocol, modify or read function code parameters, and read inverter working status and fault information, etc.

1. Agreement

The serial communication protocol defines the content and format of information transmitted in serial communication. These include: host polling (or broad broadcast) format; the encoding method of the host, including: the function code of the required action, transmission data and error checking, etc. The sound from the machine Should also adopt the same structure, including: action confirmation, return data and error checking, etc. If the slave is receiving information When an error occurs, or the action required by the host cannot be completed, it will organize a fault message as a response and feed it back to the host.

Application method

Inverter is connected to the " single master and multiple slaves " PC/PLC control network with RS485 bus as a communication slave.

Bus structure

(1) Hardware interface

Comes with communication interface A+, B- terminals.

(2) Topological structure

Single-master multi-slave system. Each communication device in the network has a unique slave address, one of which is used as a communication host (PC upper computer, PLC, HMI, etc.), the host initiates communication, and performs parameter read or write operations on the slave, and other devices are in the As a communication slave, it responds to inquiries or communication operations from the host to the machine. Only one device can send data at a time, while other devices are receiving.

The setting range of the slave address is 1 ~ 247, and 0 is the broadcast communication address. The slave address must be unique in the network.

(3) Communication transmission method

Asynchronous serial, half-duplex transmission mode. In the process of serial asynchronous communication, the data is sent one frame at a time in the form of a message. It is stipulated in the MODBUS-RTU protocol that when the idle time of no data on the communication data line is greater than the transmission time of 3.5Byte , it means a new one. Start of communication frame.

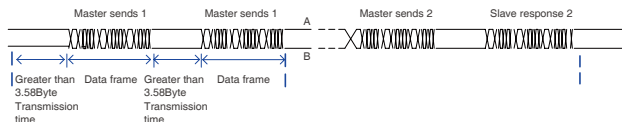

The built-in communication protocol of the inverter is the Modbus-RTU slave communication protocol, which can respond to the "query / command" of the host, or make corresponding actions according to the "query/command" of the host, and respond with communication data .

host can refer to a personal computer (PC), industrial control equipment or a programmable logic controller (PLC), etc. The host can not only communicate with a slave, but also issue broadcast information to all lower slaves. For the independent access "query / command" of the host, the accessed slave must return a response frame rate; for the broadcast information sent by the host,the slave does not need to feedback the response to the host.

(4) Communication data structure

Modbus protocol is as follows, and the inverter only supports reading or writing of Word type parameters. The corresponding communication read operation command is 0x03 ; the write operation command is 0x06 , which does not support byte or bit read and write operations:

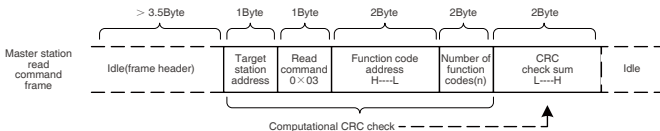

Theoretically, the upper computer can read several consecutive function codes at one time (that is, n can reach up to 12) , but be careful not to cross the last function code of this function code group, otherwise an error will be answered.

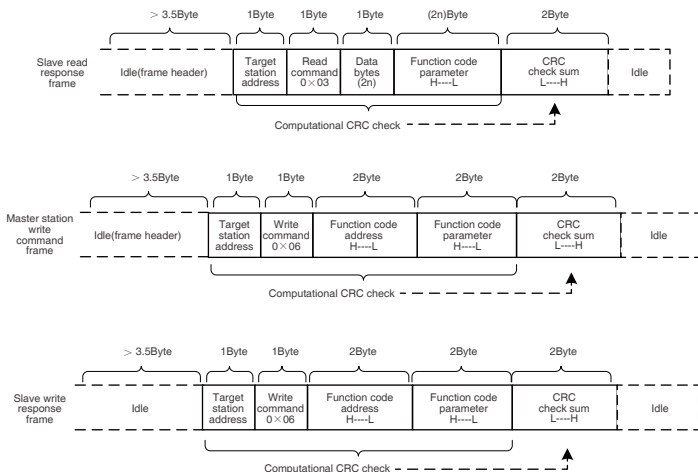

If the slave detects a communication frame error, or the read and write fails due to other reasons, it will reply with an error frame.

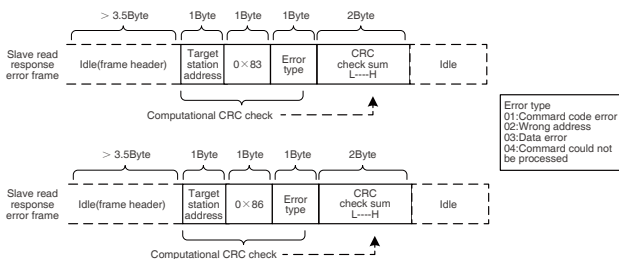

Data frame field description:

Frame header START	Idle for more than 3.5 character transfer times
Slave address ADR	Communication address range: 1~247 ; 0= broadcast address

Command code CMD	03: read slave machine parameters; 06: write slave machine parameters
Function code address H	The parameter address inside the Frequency Inverter, expressed in hexadecimal ; it is divided into functional code type and non-functional code type (such as running status parameters, Run commands, etc.) parameters, etc., see address definition for details. When transmitting, the high byte comes first and the low byte follows.
Function code address L	
Number of function codes H	The number of function codes read in this frame, if it is 1 , it means read 1 function code. When transmitting, the high byte comes first and the low byte follows. This protocol can only rewrite one function code at a time, without this field.
Number of function codes L	
Data H	Response data, or specially written data, when transmitting, the high byte comes first and the low byte follows.
Data L	
CRC CHK high bit	Detection value: CRC16 check value. When transmitting, the high byte comes first and the low byte follows. For the calculation method, see the description of the CRC check in this section.
CRC CHK low bit	
END	3.5 character time

CMD check method :

Check method — CRC check method: CRC (Cyclical Redundancy Check) uses the RTU frame format, and the message includes an error detection field based on the CRC method. The CRC field checks the content of the entire message. The CRC field is two bytes and contains a 16 -bit binary value. It is calculated by the transmitting device and added to the message. The receiving device recalculates the CRC of the received message and compares it with the value in the received CRC field. If the two CRC values are not equal, it means that there is an error in the transmission.

CRC is stored in 0xFFFF first , and then calls a process to compare the continuous 8 -bit bytes in the message with the value in the current register line processing. Only the 8Bit data in each character is valid for CRC , and the start and stop bits and parity bits are all invalid.

CRC generation, each 8-bit character is individually exclusive or (XOR) with the contents of the register, and the result moves towards the least significant bit, and the most significant bit is filled with 0. The LSB is extracted and detected. If the LSB is 1, the register is exclusive or different from the preset value. If the LSB is 0, it will not be performed. The whole process is repeated 8 times. After the last bit (bit 8) is complete, the next

Each 8-bit byte is individually exclusive-ored with the current value of the register. The value in the final register is the CRC value after all bytes in the message have been executed.

CRC is added to the message, the low byte is added first, followed by the high byte. The simple function of CRC is as follows:

```

unsigned int CRC16_CHK(unsigned char *data, unsigned char length)
{
    int j = 0;
    unsigned int reg_crc = 0xffff;
    while(length-->0)
    {
        reg_crc ^= *data++;
        for(j=0;j<8;j++)
        {
            if(reg_crc & 0x01)
            {
                reg_crc = (reg_crc >> 1) ^ 0xa001;
            }
            else
            {
                reg_crc = reg_crc >> 1;
            }
        }
    }
    return reg_crc;
}

```

- Function code parameter address marking rules:

Read and write function code parameters (some function codes cannot be changed and are only used by the manufacturer or monitored):

Use the function code group number and label as the parameter address to express the rules:

High byte: P0~PF (Group P), A0~AF (Group A), 70~7F (Group U)

Low byte: 00~FF

For example: if you want range function code P3-12, then the access address of the function code is expressed as F30C H

Notice:

PF group: parameters cannot be read or changed;

U : can only read, but cannot change parameters.

Some parameters cannot be changed when the inverter is running; some parameters cannot be changed no matter what state the inverter is in;

When changing the function code parameters, pay attention to the range, unit and related instructions of the parameters.

Function code group number	Newsletter access address	Comm modifies RAM Function code address
P0 ~ PE group	0xF000 ~ 0xFEFF	0x0000 ~ 0x0EFF
A0 ~ AC group	0xA000 ~ 0xACFF	0x4000 ~ 0x4CFF
U0 group	0x7000 ~ 0x70FF	Read only, not writable

Notice:

1. Since the EEPROM is frequently stored, the service life of the EEPROM will be reduced . Therefore, some function codes do not need to be stored in the communication mode, and only need to change the value in RAM .

2. If it is a P group parameter, to realize this function, just change the high bit F of the function code address to 0 . If it is a group A parameter, to realize this function, just change the high bit A of the function code address to 4 .

Write the corresponding function code address of RAM as follows:

High byte: 00~0F (P group), 40~4F (A group)

Low byte: 00~FF

For example: function code P3-12 is not stored in EEPROM , and the address is expressed as 030C H;

function code A0-05 is not stored in EEPROM , and the address is represented as 4005 H;

Notice:

This address indicates that it can only be used for writing to RAM , and cannot be used for reading. When reading, it is an invalid address. For all parameters, you can also use the command code 07H to realize this function.

- Shutdown / Run Parameters section:

Parameter address	Parameter Description	Parameter address	Parameter Description
1000H	Communication setting value (decimal) -10000~10000	1010 H	PID setting
1001H	Operating frequency	1011 H	PID feedback
1002H	Bus voltage	1012 H	PLC steps
1003H	The output voltage	1013 H	Input pulse frequency, Unit 0.01kHz
1004H	Output current	1014 H	Feedback speed, unit 0.1Hz
1005H	Output Power	1015	Remaining run time
1006H	Output torque	1016	AI1 voltage before correction
1007H	Running speed	1017	AI2 voltage before correction
1008H	DI input flag	1018	AI3 voltage before correction
1009H	DO output flag	1019	Line speed
100AH	AI1 voltage	101A	Current power-on time
100BH	AI2 voltage	101B	Current running time
100CH	AI3 voltage	101C	Input pulse frequency, unit 1Hz
100DH	Count value input	101D	Communication settings
100EH	Length value input	101E	Actual feedback speed
100FH	Load speed	101F	Main frequency X display
		1020	Auxiliary frequency Y display

Notice:

1. The communication setting value is a percentage of the relative value, 10000 corresponds to 100.00% , and -10000 corresponds to -100.00% .

2. For frequency dimension data, the percentage is the percentage relative to the maximum frequency (P0-10); for torque dimension data, the percentage is P2-10 , A2-48 , A3-48 , A4-48 (Torque upper limit digital setting, respectively corresponding to the first, second, third and fourth motors).

- Control command input to the inverter: (write only)

Command word address	Command function
2000H	0001: Forward running
	0002: Reverse operation
	0003: Forward jogging
	0004: Reverse jog
	0005: Free stop
	0006: Deceleration to stop
	0007: Fault reset

- Read inverter status: (read only)

Status word address	Status word function
3000H	0001: Forward running
	0002: Reverse operation
	0003: Stop

- Parameter lock password verification: (if the return is 8888H , it means the password verification is passed)

Password address	Enter the content of the password
1F00H	*****

- Digital output terminal control:(write only)

Command address	Command content
2001H	BIT0: FM output control BIT1: AO2 output control BIT2: RELAY1 output control BIT3: RELAY2 output control BIT4: FMR output control BIT5: VDO1 BIT6: VDO2 BIT7: VDO3 BIT8: VDO4 BIT9: VDO5

- Analog output AO1 control: (write only)

Command address	Command content
2002H	0~7FFF means 0 %~ 100 %

- Analog output AO2 control: (write only)

Command address	Command content
2003H	0~7FFF means 0 %~ 100 %

- Analog output AO2 control: (write only)

Command address	Command content
2004H	0~7FFF means 0 %~ 100 %

- Inverter fault description

Inverter fault address	Inverter fault information
8000H	0000: No fault 0001: Reserved 0002: Acceleration overcurrent 0003: Deceleration overcurrent 0004: Constant speed overcurrent 0005: Acceleration overvoltage 0006: Deceleration overvoltage 0007: Constant speed overvoltage 0008: Buffer resistor overload fault

Inverter fault address	Inverter fault information
8000H	0009: Undervoltage fault 000A: Inverter overload 000B: Motor overload 000C: Input phase loss 000D: Output phase loss 000E: Module overheating 000F: External fault 0010: Abnormal communication 0011: Abnormal contactor 0012: Current detection failure 0013: Motor tuning failure 0014: Encoder /PG card failure 0015: Abnormal reading and writing of parameters 0016: Inverter hardware failure 0017: The motor is short-circuited to the ground 0018: Reserved 0019: Reserved 001A: Run time reached 001B: User-defined fault 1 001C: User-defined fault 2 001D: The power-on time is reached 001E: Load off 001F: Loss of PID feedback while running 0028: Fast current limit timeout fault 0029: Switching motor failure while running 002A: The speed deviation is too large 002B: Motor over speed 002D: Motor over temperature 005A: Encoder line number setting error 005B: No encoder connected 005C: Initial position error 005E: Speed feedback error

• PD group communication parameter description

Pd-00	Baud rate	Factory default	6005
	Setting range	MODUBS baud rate	
	0: 300BPS	5: 9600BPS	
	1: 600BPS	6: 19200BPS	
	2: 1200BPS	7: 38400BPS	
	3: 2400BPS	8: 57600BPS	
	4: 4800BPS	9: 115200BPS	

This parameter is used to set the data transmission rate between the upper computer and the inverter. Note that the baud rate set by the upper computer and the inverter must be consistent, otherwise, the communication cannot be carried out. The higher the baud rate, the faster the communication speed.

	Data Format	Factory default	0
Pd-01	Setting range	0: No parity: data format <8,N,2> 1: Even check: data format <8,E,1> 2: Odd parity: data format <8, O, 1> 3: No parity: data format <8-N-1>	

- The data format set by the upper computer and the inverter must be consistent, otherwise, the communication cannot be carried out.

	Local address	Factory default	1
Pd-02	Setting range	1~247 , 0 is broadcast address	

When the local address is set to 0 , it is the broadcast address to realize the broadcast function of the host computer.

The local address is unique (except the broadcast address), which is the basis for realizing the point-to-point communication between the upper computer and the Frequency Inverter.

	Response delay	Factory default	2ms
Pd-03	Setting range	0~20ms	

Response delay: refers to the interval between the end of the inverter receiving data and sending data to the upper computer. If the response delay is small If the response delay is longer than the system processing time, the response delay is longer than the system processing time. After the system finishes processing the data, it will wait until the response delay time is up before sending data to the host computer.

	Communication timeout	Factory default	0.0 s
Pd-04	Setting range	0.0 s (Inactive) 0.1~60.0s	

When this function code is set to 0.0 s , the communication timeout parameter is invalid.

When this function code is set to a valid value, if the interval between one communication and the next communication exceeds the communication timeout time, the system will report a communication failure error (Err16). Normally, it is set to invalid. If in a system with continuous communication, By setting the secondary parameters, you can monitor the communication status.

Pd-05	Communication Protocol Selection	Factory default	0
	Setting range	0: non-standard Modbus protocol; 1: Standard Modbus protocol	

Pd-05=1: Select standard Modbus protocol.

Pd-05=0: When reading the command, the number of bytes returned by the slave is one byte more than the standard Modbus protocol,

Pd-06	Communication reading current resolution	Factory default	0
	Setting range	0 : 0.01A 1 : 0.1A	

It is used to determine the output unit of the current value when the communication reads the output current.

- Function code data

The function code data is an important setting parameter of the inverter. There are group P and group A function parameters. The parameter groups are as follows:

Function code data	P (readable and writable)	P0 , P1 , P2 , P3 , P4 , P5 , P6 , P7 , P8 , P9 , PA , PB , PC , PD , PE , PF
	A (readable and writable)	A0 , A1 , A2 , A3 , A4 , A5 , A6 , A7 , A8 , A9 , AA , AB , AC , AD , AE , AF

- The function code data communication address is defined as follows:

When reading function code data for communication, for P0~PF , A0~AF group function code data, the upper sixteen digits of the communication address are directly the function group number, and the lower sixteen digits

are directly the serial number of the function code in the function group.

Examples are as follows:

P0-16 function parameter: its communication address is F 010H, where F 0H represents the function parameter of P0 group, and 10H represents the hexadecimal data format of serial number 16 in the function group.

AC-08 function parameters: its communication address is AC08, where ACH represents the function parameters of AC group, and 08H represents the hexadecimal data format of the function code in the function group number 08

When writing function code data for communication, for P0 ~ PF group function code data, the high sixteen bits of the communication address are divided into 00 ~ 0F or F 0 ~ F F according to whether it is written into EEPROM, and the low sixteen bits are directly It is the serial number of the function code in the function group, for example as follows:

Write function in parameter P0-16 :

Writing to EEPROM, its communication address is F010H.

Not necessary to write to EEPROM , its communication address is 0010H.

When writing EEPROM data for communication, for the function code data of group A0 ~ AF , the high sixteen bits of the communication address are divided into 10 ~ 4F or A0 ~ AF, and the low sixteen bits are directly the serial number of the function code in the function group. Examples are as follows:

Write function parameter AC-08:

Writing to EEPROM , its communication address is AC08H.

Not necessary to write to EEPROM , its communication address is 4C08H.

• Non-function code data

Non-function code data	Status data (readable)	U monitoring parameters, inverter fault description, inverter running status
	Control parameters (writable)	Control command, communication setting value, digital output terminal control, analog output AO1 control, analog output AO2 control, high-speed pulse (FMP) output control, parameter initialization

- Status data

State data is divided into U group monitoring parameters, inverter fault description, and inverter running status.

1. Group U parameter monitoring parameters

U monitoring data, see the function description of group U0 in the manual, and its address is defined as follows:

U0 ~ UF , the high sixteen bits of the communication address are 70 ~ 7F, and the low sixteen bits are the serial numbers of the monitoring parameters in the group, examples are as follows:

U0-11 , its communication address is 700BH.

- Inverter fault description

When the communication reads the inverter fault, the communication address is fixed at 8000H, and the host computer can obtain the current inverter fault code by reading the address data. The description of the fault code is defined in Chapter 5 P9-14 function code.

- Inverter running status

When the communication reads the running status of the inverter, the communication address is set to 3000H, and the upper computer can obtain the current running status information of the inverter by reading the data of this address, which is defined as follows:

Inverter running state communication address	Read status word definition
3000H	1: Forward running
	2: Reverse operation
	3: Shutdown

- Control parameters

Control parameters are divided into control command, digital output terminal control, analog output AO1 control, analog output AO2 control, high-speed pulse (FMP) output control.

- Control commands

When P0-02 (command source) is selected as 2 : communication control,

the upper computer can realize the start-stop and other related command control of the inverter through the communication address. The control command is defined as follows:

Control command communication address	Command function
2000H	1: Forward running
	2: Reverse operation
	3: Forward jogging
	4: Reverse jog
	5: Free stop
	6: Deceleration to stop
	7: Fault reset

- Communication settings

The communication setting value is mainly used for the given data when the medium frequency source, torque upper limit source, VF separation voltage source, PID given source, PID feedback source, etc. are selected as communication given. The communication address is 1000H, and the host computer sets. When the communication address is valued, its data range is -10000 ~ 10000, corresponding to the relative given value -100.00%-100.00%.

- Digital output terminal control

When the function of the digital output terminal is selected as 20 : communication control, the upper computer can realize the control of the digital output terminal of the inverter through the communication address, which is defined as follows:

Digital output terminal control communication address	Command content
2001H	BiT0: FM output control BiT1: AO2 output control BiT2: RELAY1 output control BiT3: RELAY2 output control BiT4: FMR output control BiT5: VDO1 BiT6: VDO2 BiT7: VDO3 BiT8: VDO4 BiT9: VDO5

- Analog output AO1 , AO2, high-speed pulse output FMP control

When the analog output AO1 , AO2 , high-speed pulse output FMP output function is selected as 12 : communication setting, the upper computer can realize the control of the inverter analog and high-speed pulse output through the communication address, defined as follows:

Output control communication address		Command content
AO1	2002H	0~7FFF means 0%~100%
AO2	2003H	
FMP	2004H	

- Parameter initialization

This function needs to be used when it is necessary to realize the parameter initialization operation of the inverter through the host computer.

If PP-00 (user password) is not 0 , it is necessary to pass the password verification first, after the verification is passed, after 30 seconds, the upper computer will perform parameter initialization.

The communication address for user password verification by communication is 1F00H, and the correct user password can be directly written into this address to complete the password verification.

The address for parameter initialization for communication is 1F01H, and its data content is defined as follows:

Parameter initialization communication address	Command function
1F01H	1: Restore factory parameters
	2: Clear record information
	4: Restore user backup parameters
	501: Back up the user's current parameters

Appendix B European Fire Mode Functional Applications

- Terminal function code set P4-00~P4-06 added terminal function code 55:
55: Fire mode trigger terminal
- New function code:

P8-55	Fire mode selection	Ex-factory value	0
		Setting range	0: No function 1: Fire Mode 1 2: Fire Mode 2 3: Fire Mode 3 4: Fire Mode 4
P8-56	Force run frequency	Ex-factory value	50.00Hz
		Setting range	0.00 Hz~ Maximum Frequency (P0-10)
P8-58	Fire Drill Time	Ex-factory value	0.0s
		Setting range	0.0s~6553.5s Note: Drill cannot be started when time is set to 0.

Fire function application:

P8-55=0 No function. Even if the fire mode trigger terminal (55) of the P4 group is triggered, it is invalid.

P8-55=1 (fire mode 1) The start-stop control of the inverter is determined by the P0-02 selection, and the frequency source is determined by the P0-03 selection. The fire mode trigger terminal (55) triggers the fire mode but it (55) can't start the inverter. Once the terminal (55) is removed, the inverter can be shut down by the command source. The mode 1 is mainly used to debug the fire mode.

P8-55=2 (fire mode 2) The fire mode trigger terminal (55) triggers the fire mode, but it (55) can't start the inverter. The inverter needs to be started by the starting mode selected by the command source (P0- 03). When the inverter is started and the fire mode triggered, the removal of starting terminal or the fire mode trigger terminal will not shut down the inverter. The mode 2 can be used to verify fire mode or fire drills.

P8-55=3 (fire mode 3) The fire mode triggers terminal (55) triggers the fire mode and the inverter operates at a forced frequency (P8-56), any stop command can't shut down the inverter until power failure or machine damage. The mode 3 is suitable for use in real fire situations.

P8-55=4 (fire mode 4) The fire mode triggers terminal (55) triggers the fire mode. The inverter operates at a forced frequency (P8-56) and lasts for a fire drill time (P8-53). The inverter cannot be shut down until the drill time is reached. Once the drill time is reached, the inverter will stop automatically. If the terminal (55) triggers again, the fire mode will be retriggered and the timing will restart. Note: The mode 4 can't be triggered when the Fire Drill Time (P8-53) value is 0. The mode 4 is suitable for real fire situations and fire drills.

Note:

1. Because of the forced operation frequency in mode 3 and 4, when the fire mode triggers terminal (55) triggers, the frequency source P0-03 will be forced to switch to 1: 'Digital setting'.

2. If the fire mode triggers terminal (55) fails, in the mode 1:

- The inverter can be shut down by a stop command.
- If a fault occurs, the inverter will display an error code.

This mode 1 is mainly used for fire mode function debugging, not for standard fire mode.

3. When the fire mode is activated, the inverter will not stop until the power is cut off or the machine is blown up.

4. Even if the inverter is in a fault state, as long as the inverter is not damaged, the fault will be forced to be cleared and the inverter will be forced to start when the fire mode is triggered.

5. The rotation operation by default in fire mode is forward. Reverse operation or reverse jog can be realized when other terminals are set for this purpose. If you want to prohibit reverse operation or reverse jog in fire mode, you need to set the terminal function that is not used by the P4 function group to 0 : No function.

Warning: Determine the consequences of property damage or personal safety accidents caused by fire mode.

Product after-sales service policy

The company solemnly promises that, from the day the user purchases the product from our company (hereinafter referred to as the manufacturer), the user enjoys the following after-sales warranty services for the product.

1. This product has a 24-month free warranty from the date of purchase from the manufacturer (except for products exported to foreign countries/non-standard machines).

2. If the product has quality problems within one month from the date of purchase by the user from the manufacturer, the manufacturer will guarantee refund, replacement and warranty.

3. If the product has quality problems within three months from the date of purchase by the user from the manufacturer, the manufacturer will guarantee replacement and warranty.

4. This product enjoys paid lifetime service from the date of purchase from the manufacturer.

5. Disclaimer: Product failures caused by the following reasons are not within the scope of the manufacturer's 24-month free warranty service commitment:

(1) The user does not operate correctly according to the procedures listed in the "Product Manual";

(2) The user repairs the product without communicating with the manufacturer or modifies the product without authorization, resulting in product failure;

(3) The use of the product in the standard scope of use of the product in the user's country of origin causes product failure;

(4) The user's poor use environment leads to abnormal aging of product components or causes failures;

(5) Product damage caused by force majeure such as earthquake, fire, wind and flood disasters, lightning strike, abnormal voltage or other natural disasters;

(6) During the transportation process after the user purchases the product, the product is lost due to improper selection of the transportation method or other external force intrusion; (the transportation method is reasonably selected by the user, and the company assists in handling the consignment procedures)

6. The manufacturer has the right not to provide warranty service under the following circumstances:

(1) When the brand, trademark, serial number, nameplate and other marks marked by the manufacturer on the product are damaged or unrecognizable;

(2) When the user fails to pay off the purchase price in accordance with the "Purchase and Sales Contract" signed by both parties;

(3) When the user deliberately conceals the improper use of the product during installation, wiring, operation, maintenance or other processes from the after-sales service provider of the manufacturer.

7. Janson Controls Technologies (Shenzhen) Co., Limited reserves the final interpretation right of this policy.



JANSON CONTROLS

Janson Controls Technologies(Shenzhen)Co.,Limited

📍 **Add:** 3rd Floor, Building E, Fuxing Industrial Park,
No.110, Zhangqi Road, Guixiang Community,
Guanlan Street, Longhua District, Shenzhen, China.

☎ **Tel:** +86-0755-29611160

🌐 **http:** //www.jansoncontrols.com

✉ **Email:** info@jansoncontrols.com

